

# Webasto Unite

## Webasto Charging Solutions



EN	Operating- and Installation Instructions.....	2
----	---	---

# Table of Contents

<b>1 Quick Start Guide for App Solutions</b>	<b>3</b>
<b>2 General Information</b>	<b>4</b>
2.1 Purpose of the document	4
2.2 Using this document	4
2.3 Intended use	4
2.4 Use of symbols and highlighting	4
2.5 Warranty and liability	4
<b>3 Safety</b>	<b>5</b>
3.1 General information	5
3.2 General safety information	5
3.3 Safety information for installation	5
3.4 Safety information for electrical connection	6
3.5 Safety information for initial start-up	6
3.6 Safety information for cleaning	6
3.7 Safety information for replacing the charging cable	6
<b>4 Scope of delivery</b>	<b>7</b>
<b>5 Required tools</b>	<b>8</b>
<b>6 Installation and electrical connection</b>	<b>9</b>
6.1 Opening the charging station cover	9
6.2 Wall mounting the charging station	9
6.3 Using a 1-phase AC mains connection	10
6.4 Using a 3-phase AC mains connection	11
6.5 Using the cable glands	12
6.6 Adjusting the current limiter	12
6.7 Setting the DIP switches	13
6.8 Using the Mode selection switch	16
6.9 Setting up Load shedding / Potential-free contact	16
6.10 Monitoring welded relay contact failures	17
6.11 Resetting RFID card lists and registering new master RFID cards	17
6.12 Configuring a charging station's Ethernet port	17
6.13 Enabling and disabling the web configuration interface	17
6.14 Configuring an OCPP connection	18
6.15 Final step	18
<b>7 Commissioning the charging station</b>	<b>19</b>
7.1 Connecting your computer and your smart board to the same network	19
7.2 Accessing the Unite configuration interface using a web browser	19
7.3 Accessing the Unite configuration interface via Wi-Fi hotspot	19
<b>8 Unite Configuration Interface</b>	<b>20</b>
8.1 Main page	20
8.2 General Settings	20
8.3 Installation Settings	20
8.4 OCPP Settings	22
8.5 Network Interfaces	22
8.6 Standalone Mode	23
8.7 Local Load Management	23
8.8 System Maintenance	25
<b>9 Setting up charging</b>	<b>26</b>
9.1 Charging cable plug	26
9.2 Reading the status information LED	26
9.3 Standalone / Offline Usage modes	27
9.4 OCPP Connected mode	29
<b>10 MID meter models</b>	<b>30</b>
<b>11 Troubleshooting</b>	<b>31</b>
11.1 Resetting to factory defaults	31
11.2 General error condition	32
11.3 DC 6 mA leakage current sensor behavior	32
<b>12 Disposal</b>	<b>33</b>
<b>13 Declaration of Conformity</b>	<b>33</b>
<b>14 Cleaning and maintenance</b>	<b>33</b>
<b>15 Technical data</b>	<b>34</b>
15.1 Model description	34
15.2 Dimensional drawings	34
15.3 Models	34
15.4 Technical specifications	35
<b>16 Checklist for the installation of the Webasto charging station</b>	<b>36</b>

# 1 Quick Start Guide for App Solutions

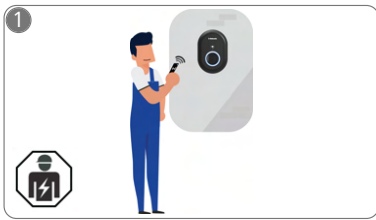

✓ The Webasto Unite must be installed by a qualified electrician.



↓ Download the required Apps:  
 1) For installation:  
 Webasto Charger Setup  
 2) For operation:  
 Webasto ChargeConnect

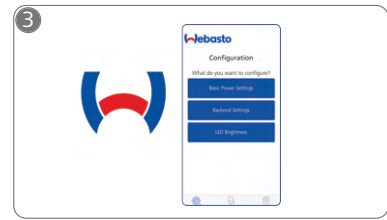

☞ Open the Webasto Charger Setup app and configure your charging station.

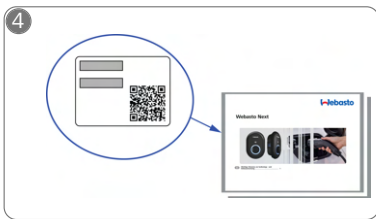

👁 Scan the QR code on the label in the Quick Start Guide or type in the Wi-Fi password manually.



☞ Open the ChargeConnect app and follow the steps to connect the charging station to the ChargeConnect Cloud.



⚡ Plug in and enjoy exploring your charging station's capabilities.

## 2 General Information

### 2.1 Purpose of the document

These operating and installation instructions are part of the product and contain information for the user to ensure safe operation and for the electrician to carry out safe installation of the Webasto Unite charging station. In addition to the "Important Information on Operating and Installation Instructions", a printed version of which is enclosed with your product, this document also contains detailed information about operating the product.

### 2.2 Using this document

- ▶ Carefully read these operating and installation instructions for safe operation and installation of the Webasto Unite.
- ▶ Keep these instructions ready to hand.
- ▶ Hand this document on to the following owner or user of the charging station.

Your "Important Information on Operating and Installation Instructions", a printed version of which is enclosed with your product, includes introductory information and information relevant to safety and installation. This document additionally includes further information on the operation of the charging station.

 **NOTE**

We would draw your attention to the fact that, as part of a professional installation, an installation log should be drawn up by the installer. We also request that you fill in our Check list for the installation of the Webasto charging station.

 **NOTE**

Individuals with deficiency in their colour vision require support in the allocation of all fault indicators.

### 2.3 Intended use

The Webasto Unite charging station is designed for charging electric vehicles in accordance with IEC 61851-1, charge mode 3.

In this charge mode, the charging station ensures:

- The voltage is not applied before the vehicle has been connected correctly.
- The maximum power is calibrated.

### 2.4 Use of symbols and highlighting



**DANGER**

This signal word denotes a hazard with a **high** degree of risk which, if not avoided, may lead to death or serious injury.



**WARNING**

This signal word denotes a hazard with a **moderate** degree of risk which, if not avoided, may lead to minor or moderate injury.



**CAUTION**

This signal word denotes a hazard with a **low** degree of risk which, if not avoided, may lead to minor or moderate injury.



**NOTE**

This symbol denotes a special technical feature, or (if not observed) potential damage to the product.



This symbol refers to separate documents which may be enclosed or can be requested from Webasto.

### 2.5 Warranty and liability

Webasto shall not assume liability for defects or damage that are the result of the installation and operating instructions being disregarded. This liability exclusion particularly applies for:

- Improper use.
- Repairs carried out by an electrician not contracted by Webasto.
- Use of non-original spare parts.
- Unauthorised conversion of the unit without permission from Webasto.
- Installation and commissioning by unqualified staff (not an electrician).
- Improper disposal after decommissioning.



**NOTE**

In case of any claims, defects or damage to your project, you must contact your direct contractual partner, installation partner or dealer.



**WARNING**

Installation and connection of the charging station must only be carried out by a qualified electrician.



The symbol of a bin with a line through it means that the instructions in the chapter on Disposal must be followed.

## 3 Safety

### 3.1 General information

The device must only be used in a technically faultless condition. Any malfunctions that adversely affect the safety of persons or of the device must be immediately rectified by a qualified electrician in accordance with nationally applicable regulations.

### 3.2 General safety information

#### WARNING

- Hazardous voltages are present within the casing.
- The charging station does not have its own main ON/OFF switch. The protective devices installed in the power supply system are therefore also used to disconnect the power supply.
- Check charging station for visual damage before use. Do not use the charging station if damaged.
- Installation, electrical connection and initial operation of the charging station must only be carried out by an electrician.
- Do not remove the cover of the installation area whilst in operation.
- Do not remove markings, warning symbols and the type label from the charging station.
- It is strictly prohibited to connect other equipment/devices to the charging station.
- Make sure that the charging cable and coupling cannot be driven over, trapped and are protected from any other hazards.
- Immediately notify Webasto Customer Service if the charging station, charging cable or the charging coupling are damaged. Do not continue using the charging station.
- Prevent the charging cable and coupling from coming in contact with external heat sources, water, dirt and chemicals.
- Do not attach extension cables or adapters to the charging cable.
- Remove the charging cable by pulling on the charging coupling only.
- Never clean the charging station with a high-pressure cleaner or similar device or using a garden hose.
- Switch off the power supply before cleaning the charging sockets.
- The charging cable must not be subjected to any strain during use.
- Ensure only persons who have read these operating instructions have access to the charging station.

#### WARNING

- When not in use, store the charging cable in the designated holder and lock the charging coupling in the remote dock. Loosely wind the charging cable around the remote dock making sure the cable does not touch the floor.
- You must make sure that the charging cable and coupling cannot be driven over, trapped and are protected from all other hazards.

### 3.3 Safety information for installation

#### WARNING

- The instructions in this document must be followed for safe installation.
- Installation and connection of the charging station must only be carried out by a qualified electrician.
- You must comply with the locally applicable requirements regarding electrical installations, fire protection, safety regulations, and escape routes at the intended installation location.
- Only use the supplied installation material.
- When open, ESD (electrostatic discharge) precautions must be taken properly to avoid electrostatic discharge.
- When handling electrostatically sensitive boards, wear grounded antistatic wrist straps and properly observe ESD safety precautions. Wrist straps must only be used when mounting and connecting the loading unit. Wrist straps must never be worn on a live Webasto Unite.
- Electricians must be properly grounded during installation of the Webasto Unite.
- Do not install the Webasto Unite in an explosion sensitive area (Ex Zone).
- Install the Webasto Unite in such a way that the charging cable does not block any passageways.
- Do not install the Webasto Unite in areas subject to ammonia or air containing ammonia.
- Do not install the Webasto Unite in a location where falling objects may damage it.
- The Webasto Unite is suitable for use indoors as well as outdoors.
- Do not install the Webasto Unite in the vicinity of water jets, such as car-wash installations, high-pressure cleaners or garden hoses.
- Protect the Webasto Unite against damage caused by sub-zero temperatures, hail or similar. We would like to refer you to our IP protection class at this juncture (IP54).
- The Webasto Unite is suitable for use in areas without access restrictions.
- Protect the Webasto Unite from direct sunlight. The charging current may be reduced at high temperatures, or charging may be disabled completely. The operating temperature is -35°C to +55°C.
- The installation location of the Webasto Unite should ensure that vehicles cannot inadvertently collide with it. Protective measures must be implemented if the possibility of damage cannot be ruled out.
- Do not put the Webasto Unite into operation if it has been damaged during installation; a replacement will be required.

### 3.4 Safety information for electrical connection

**WARNING**

- Each charging station must be protected with its own line circuit breaker and residual current circuit breaker. See Requirements installation space.
- Make sure that the electrical connections are de-energised before connecting the charging station to the power supply.
- Make sure that the correct supply cable is used for the power connection.
- Do not leave the charging station unattended with the cover open.
- Change DIP-switch settings only with the power off.
- Register with the power supply company as required.

### 3.5 Safety information for initial start-up

**WARNING**

- Initial start-up of the charging station must be carried out only by an electrician.
- Prior to initial start-up, the electrician must check that the charging station has been connected correctly.
- Do not connect a vehicle during initial start-up of the charging station.
- Before starting-up the charging station, check the charging cable, charging coupling and the charging station for visible damage. The charging station must not be started up if it is damaged or if the charging cable/charging coupling is damaged.

### 3.6 Safety information for cleaning

**DANGER****High voltages.**

Danger of fatal electric shock. Do not clean the charging station with running water.

Details on maintenance, cleaning and repair can be found in the manual.

### 3.7 Safety information for replacing the charging cable

**DANGER****Risk of fatal electric shock.**

- ▶ Switch off and secure the power supply to the charging station.

**NOTE**

Only use genuine Webasto parts.

## 4 Scope of delivery

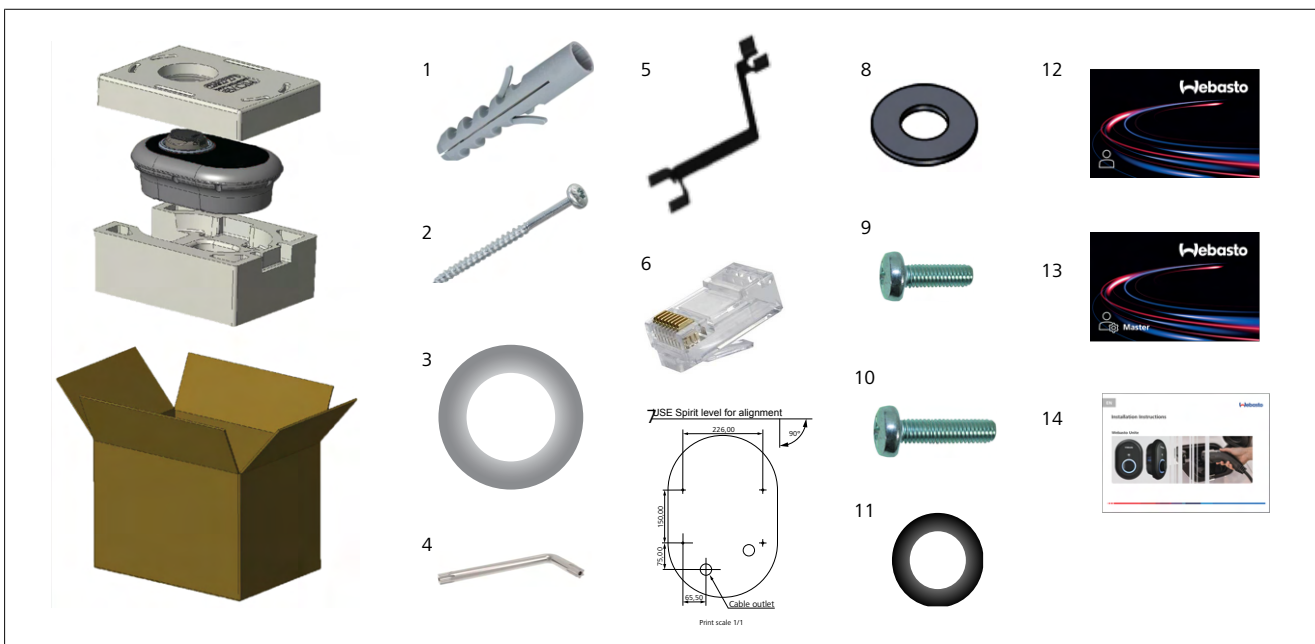













Fig. 1

Pos.	Item(s)	Usage	Quantity
1	Dowels (M8 x 50, plastic)	To mount the charging station on the wall.	4
2	Torx T25 security screw (M6 x 75)	To mount the charging station on the wall.	4
3	Gasket for screw (6 x 75)	To mount the charging station on the wall with the correct IP.	4
4	Torx T20 security L-wrench	Wrench for screws to mount the charging station on the wall with the correct IP.	1
5	Wrench	To fasten and unfastening the cable glands.	1
6	RJ45 Male connector	LAN cable connection (optional).	1
7	Mounting template	To mount the charging station to a wall.	1
8	O-ring	To mount the charging station to a pole.	3
9	Screw (M6 x 20)	To mount the charging station to a pole.	3
10	Screw (M6 x 30)	To mount the charging station, and providing earth continuity for chargers mounted on a metal surface. This screw must be inserted into the bottom hole of charging station on the wall. Place a rubber ring (11) below this screw to fix the ground cable.	1
11	IP Rubber	To fix the ground cable with the M6 x 30 screw. This rubber ring must be placed right-down the wall-mount hole of charging station, under the ground cable and the M6 x 30 screw.	1
12	User RFID Card	To start and stop charging.	2
13	Master RFID Card	To add and remove user RFID Cards to and from the local RFID list.	1
14	ISI Webasto Unite	To install the charging station safely and adequately.	1

## 5 Required tools

	8 mm drill bit
	Impact drill
	Smartphone or computer
	Voltage indicator
	Torx T25 security screwdriver
	Spirit level
	Flathead screwdriver (tip width: 2.0 - 2.5 mm)
	Pointed spudger
	Right-angle screwdriver adapter / Torx T20 security bit
	RJ45 crimping tool
	CAT5e or CAT6 Ethernet cable



## 6 Installation and electrical connection



### ATTENTION

#### High voltages

Danger of fatal electric shock.

The Webasto Unite must be installed by a qualified electrician.

### Charging station installation steps

- Installation and connection of the charging station must only be carried out by a qualified electrician.
- Make sure that the ground resistance of the installation is less than 100 ohms.
- Read these instructions before mounting your charging station.
- Do not mount your charging station on the ceiling or on a sloping wall.
- Use the specified wall mounting screws and other accessories.
- This charging station is classified as *indoor* and is *outdoor* installation compatible.  
If the charging station is installed outside a building, the hardware that is used to connect the cables to the charger must be compatible with *outdoor* use, and the charging station must be mounted accordingly to preserve the charger's IP rate.

### 6.1 Opening the charging station cover



### DANGER

Danger of fatal electric shock.

- ▶ Switch off and secure the power supply to the charging station.

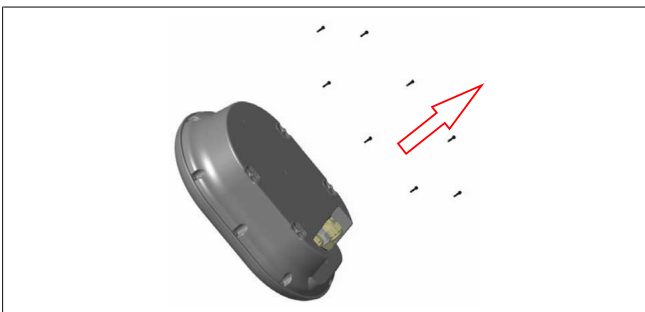

Fig. 2

1. Remove the cover screws using a Torx T20 security L-wrench, or with a right-angle screwdriver adapter with a Torx T20 security bit.

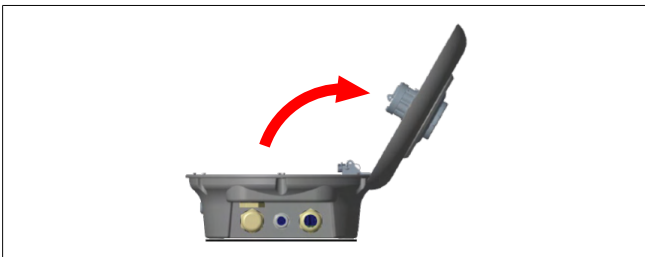

Fig. 3

2. Open the cover.

### 6.2 Wall mounting the charging station

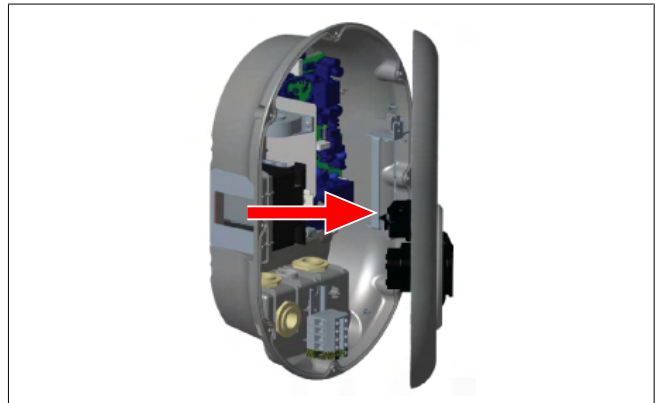

Fig. 4

1. Open the charging station's front cover (See chapter 6.1, "Opening the charging station cover" on page 9).

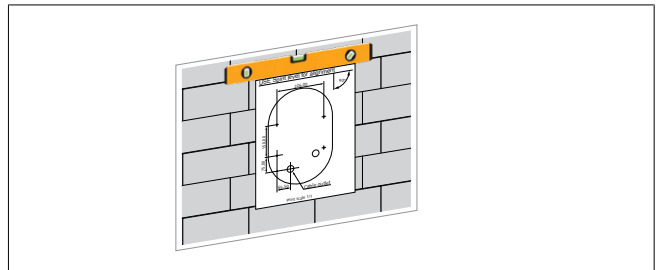

Fig. 5

2. Position the charging station on the wall by using the mounting template, and then mark the drill positions.

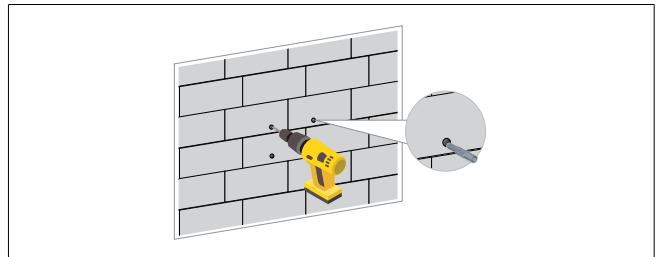

Fig. 6

3. Locate the marked drill points on the wall, and then drill the mounting holes, using an impact drill with an 8 mm drill bit.
4. Place the dowels into the drill holes.

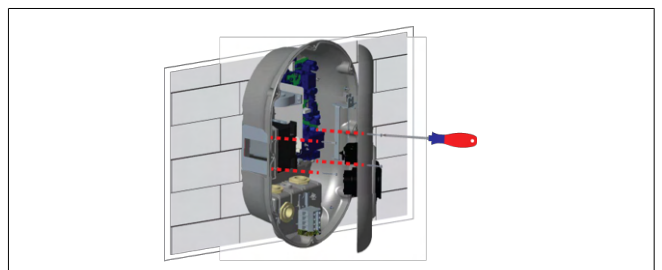

Fig. 7

5. Position the unit in line with the inserted dowels, and then secure it with the security screws (6 x 75) using a Torx T25 Security Screwdriver.

### 6.3 Using a 1-phase AC mains connection

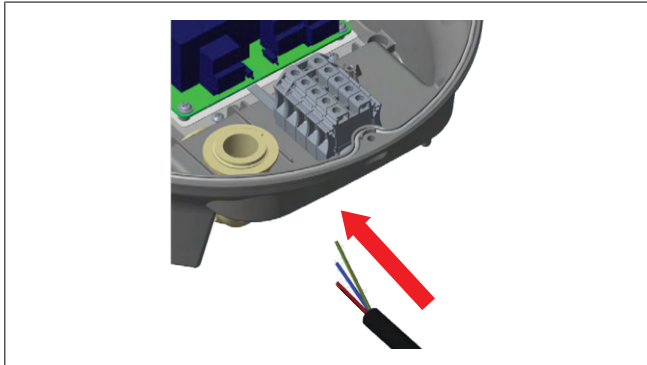

Fig. 8

1. Insert the AC mains cable into the charging station from the left cable gland at the bottom of the station.

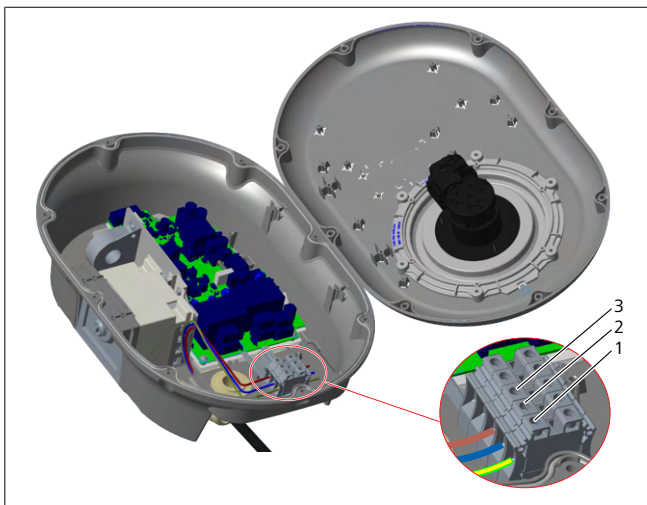

Fig. 9

Terminal	Function	Wire colour
1	Earth	Green-Yellow
2	AC Neutral	Blue
3	AC L1	Brown

1. Insert the wires into the terminal block following the colour coding in the legend.
2. Tighten the screws on the terminal block with a torque of 2.5 Nm.

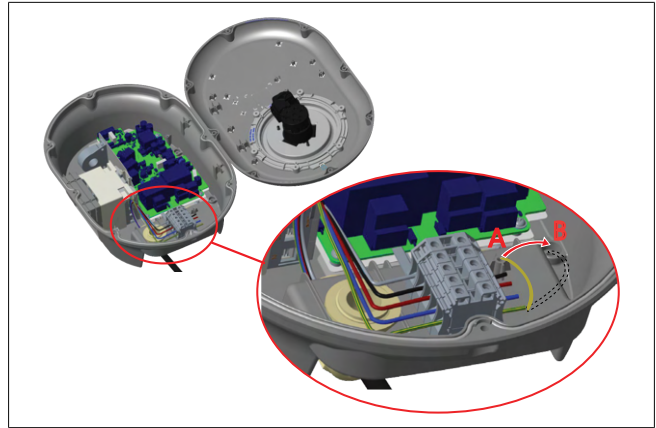

Fig. 10

3. If you mount the charging station on a conductive metal surface, such as a metal pole, you must make a connection to the earth using an extension wire for the earth (ground) and the screw at the lower right.
4. Change the position of the grounding wire from A to B to ensure grounding.
  - Insert the plastic support (this is the IP rubber supplied in the unit's accessory pack) into the fixing hole (position "B").
  - Secure the grounding cable using an M6 x 30 screw, which is in the artwork pack. This screw also secures the unit to a conductive metal surface (where applicable).
5. Tighten the cable glands before closing the charging station cover (See chapter 6.5, "Using the cable glands" on page 12).

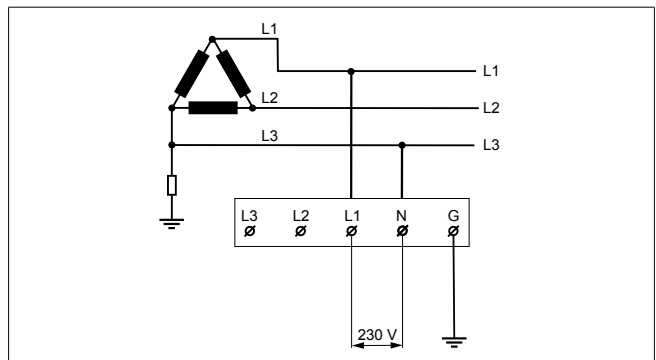

Fig. 11

Wiring diagram (for IT Grid Installation only)



**WARNING**  
**for IT Grid Installation only**

A maximum rated voltage of 230 V is permissible between L1 and L3 on the grid side.

6. For single-phase IT Grid installation, use the above wiring diagram.
7. In the web user interface, set the grounding type to "IT Grid" using the "Installation settings" menu

## 6.4 Using a 3-phase AC mains connection

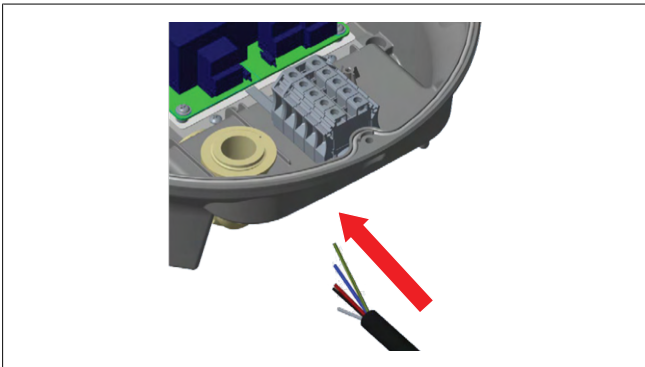

Fig. 12

1. Insert the AC mains cable into the charging station from the left cable gland at the bottom of the station.

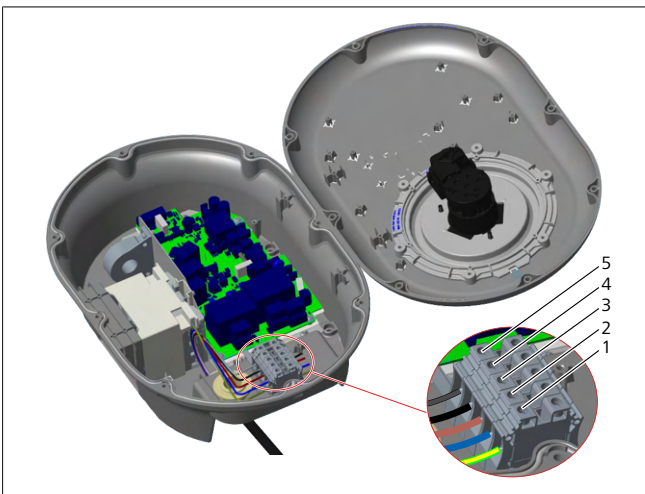

Fig. 13

Terminal	Function	Wire colour
1	Earth	Green-Yellow
2	AC Neutral	Blue
3	AC L1	Brown
4	AC L2	Black
5	AC L3	Grey

1. Insert the wires into the terminal block following the colour coding in the legend.
2. Tighten the screws on the terminal block with a torque of 2.5 Nm.

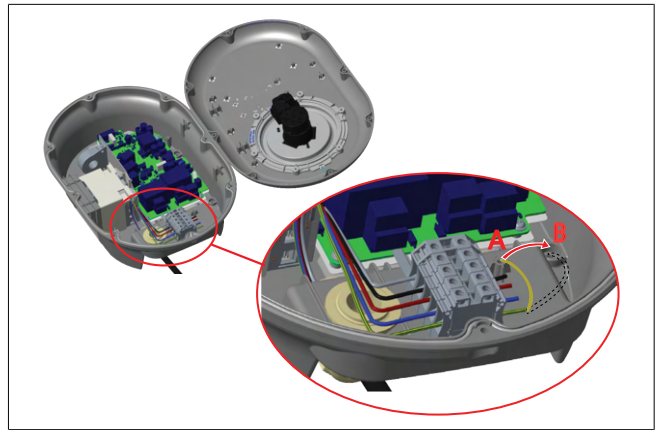

Fig. 10

3. If you mount the charging station on a conductive metal surface, such as a metal pole, you must make a connection to the earth using an extension wire for the earth (ground) and the screw at the lower right.
4. Change the position of the grounding wire from A to B to ensure grounding.
  - Insert the plastic support (this is the IP rubber supplied in the unit's accessory pack) into the fixing hole (position "B").
  - Secure the grounding cable using an M6 x 30 screw, which is in the artwork pack. This screw also secures the unit to a conductive metal surface (where applicable).
5. Tighten the cable glands before closing the charging station cover (See chapter 6.5, "Using the cable glands" on page 12).

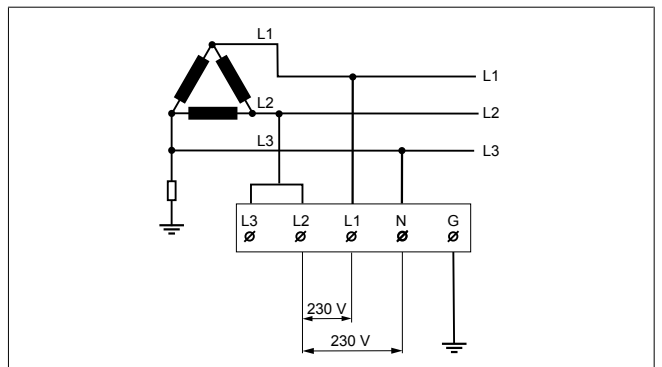

Fig. 15

Wiring diagram (for IT Grid installation only)



### WARNING for IT Grid Installation only

A maximum rated voltage of 230 V is permissible between L1 and L2 and between L2 and L3 on the grid side.

1. For three-phase IT Grid installation use this wiring diagram.
2. In the web user interface, set the grounding type to "IT Grid" using the "Installation settings" menu

### 6.5 Using the cable glands

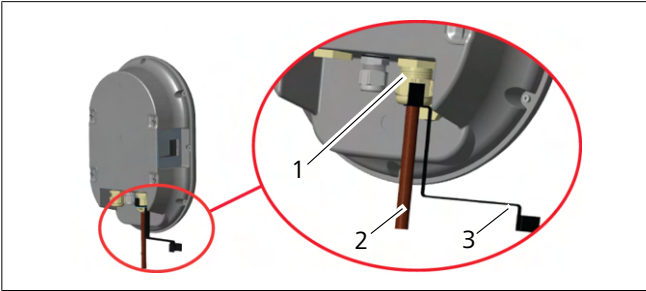

Fig. 16

Pos.	Description
1	AC mains cable gland
2	AC mains cable
3	Wrench

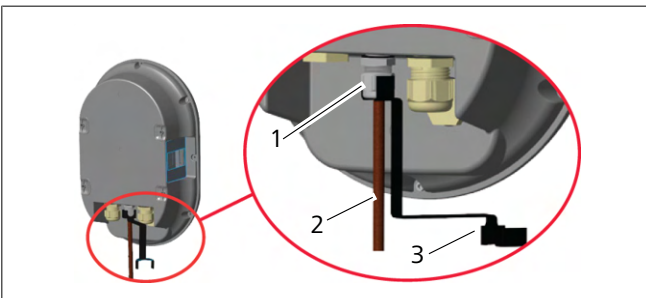

Fig. 17

Pos.	Description
1	Data cable gland
2	Data cable
3	Wrench

Proceed as follows:

1. Insert the cables (2) into the unit.
2. Tighten the cable glands (1) using the wrench (3)

### 6.6 Adjusting the current limiter

**NOTE**

**DIP-switch settings**

DIP-switch settings are optional. All settings can be changed by using the Setup App, or the web configuration interface (see chapter 8, "Unite Configuration Interface" on page 20).

- ▶ The most recent made setting will always be applied.
- ▶ The current setting is shown in the web configuration interface.

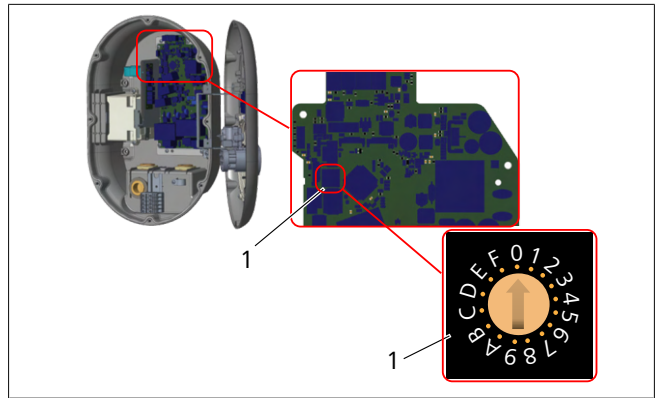

Fig. 18

1 Rotary switch current limiter settings

The charging station has a current limiter (rotary switch) on its mainboard. This switch sets the charging station's current and power limit. To change the settings, use a flathead screwdriver to gently adjust the arrow in the centre of the rotary switch by changing its position to the required-current rate. For rate details, see the table *Current limiter positions*.

Switch position	Phase	Current limit Value (22 kW)
0	1-phase	10 A
1		13 A
2		16 A
3		20 A
4		25 A
5		30 A
6		32 A
7	X	X
8	3-phase	10 A
9		13 A
A		16 A
B		20 A
C		25 A
D		30 A
E		32 A
F	X	X

**Required circuit breaker on AC mains**

Charging Station Current Limiter Setting	C-Curve MCB (miniature circuit breaker)
10 A	13 A
13 A	16 A
16 A	20 A
20 A	25 A
25 A	32 A
30 A	40 A

## 6.7 Setting the DIP switches

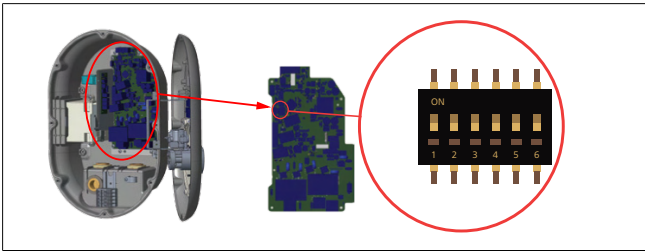

Fig. 19

1	Reserved
2	Enable Potential free contact/Load shedding
3	Locked Cable Function (only for socket models)
4, 5, 6	Power Optimizer (requires optional accessories)

**NOTE**  
**DIP-switch settings**  
 DIP-switch settings are optional. All settings can be changed by using the Setup App, or the web configuration interface (see chapter 8, "Unite Configuration Interface" on page 20).

- ▶ The most recent made setting will always be applied.
- ▶ The current setting is shown in the web configuration interface.

### 6.7.1 Enable Potential free contact/Load shedding

Your charging station can be controlled with external potential-free contacts (on/off function) for integration of the charging station into:

- car park automation systems
- energy supplier ripple control devices
- timer switches
- photovoltaic inverters
- auxiliary load control switches
- external key lock switches
- etc.

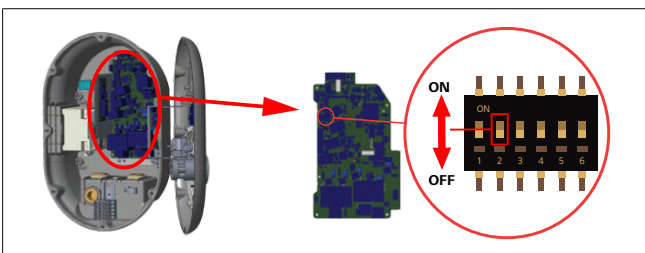

Fig. 20

ON	Enabled	OFF	Disabled
----	---------	-----	----------

1. Set DIP switch 2 in the **ON** position to **enable** the external enable function, or in the **OFF** position to **disable** the external enable function.

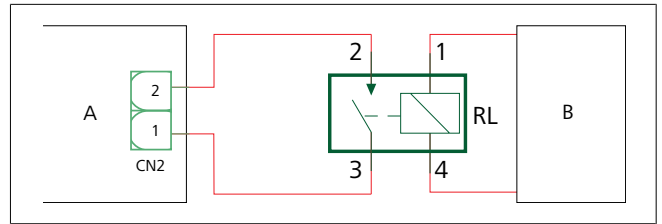

Fig. 21

Pos.	Description
CN2	Connector 2
RL	Relay
A	Main board charging station
B	Car Automation System Control

Pin assignments connector 2	
1	Pin 1
2	Pin 2

Pin assignments Relay	
1, 2	Potential free contacts
3, 4	Relay coil

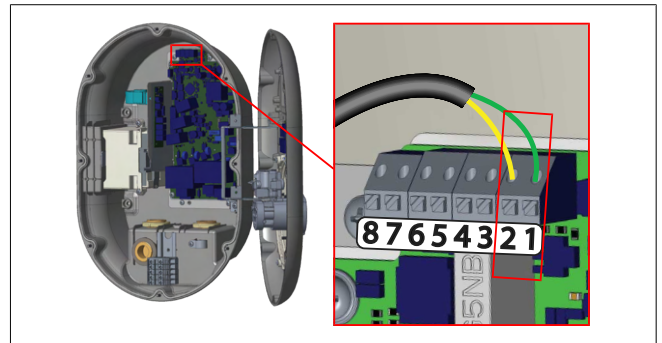

Fig. 22

Terminal	Function
1 (CN2-1)	Potential free contact /Load shedding
2 (CN2-2)	Potential free contact/Load shedding
3 (CN2-3)	Load Shedding Input +
4 (CN2-4)	Load Shedding Input -
5 (CN2-5)	Power optimizer meter B (COM)
6 (CN2-6)	Power optimizer meter A (COM)
7 (CN2-7)	-
8 (CN2-8)	-

1. Mount the wiring according to the illustration and table above.
  - Charging is disabled when the external relay contacts are in the **open** position.

**NOTE**  
**DIP-switch settings**  
 DIP-switch settings are optional. All settings can be changed by using the Setup App, or the web configuration interface (see chapter 8, "Unite Configuration Interface" on page 20).

- ▶ The most recent made setting will always be applied.
- ▶ The current setting is shown in the web configuration interface.



### 6.7.2 Data cable connection

Following data connection cables can be inserted through the cable holes:

- External enable input cable
- Power optimizer measurement cable (external meter)
- Ethernet connection cables
- Load shedding triggering signal cable
- Shunt trip module control signal cable for welded relay contact failure

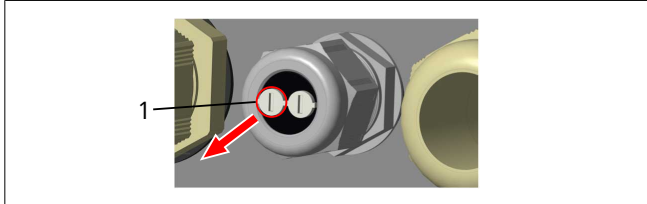

Fig. 23

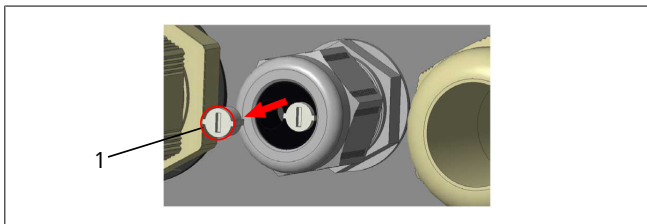

Fig. 24

1. Remove the cork (1) from the cable gland.

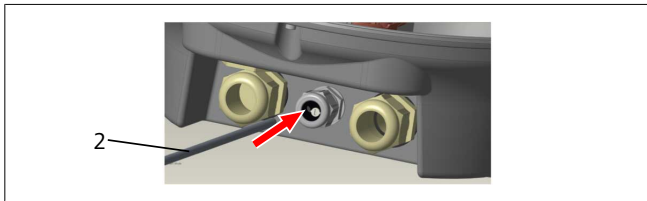

Fig. 25

2. Insert the cable (2) into the cable hole.

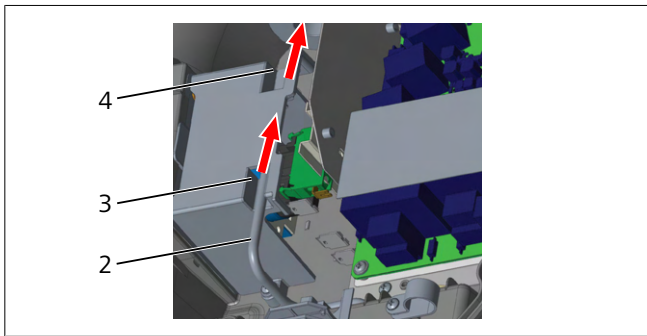

Fig. 26

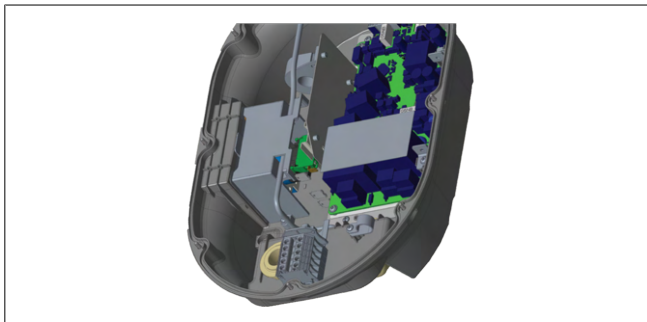

Fig. 27

3. To connect the wires to the mainboard, check the applicable sections depending on the function(s) to be used.

### 6.7.3 Locked cable function

The cable will be locked and the socket model charging station behaves like an attached cable model.

To activate this function:

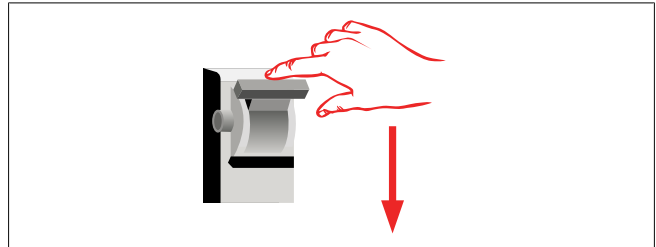

Fig. 28

1. Turn off the power to your charging station.

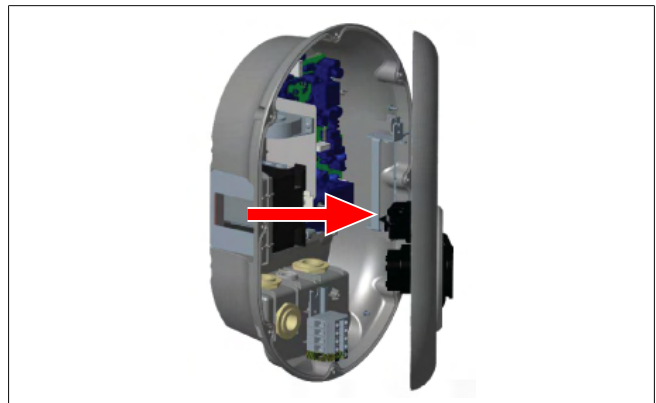

Fig. 4

2. Open the product cover as described in the installation manual.

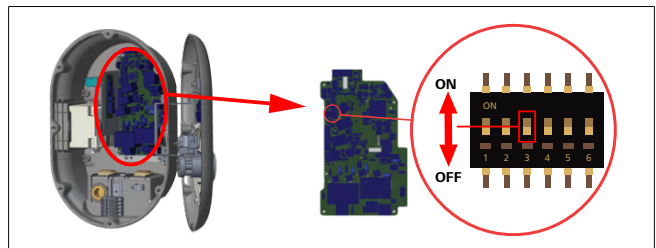

Fig. 30

ON	Enabled	OFF	Disabled
----	---------	-----	----------

3. To enable the locked cable function, toggle DIP switch 3 into the ON position using a pointed spudger or a similar plastic pointed tool. The DIP switch location is shown in the above figure.

**NOTE**

**DIP-switch settings**

DIP-switch settings are optional. All settings can be changed by using the Setup App, or the web configuration interface (see chapter 8, "Unite Configuration Interface" on page 20).

- ▶ The most recent made setting will always be applied.
- ▶ The current setting is shown in the web configuration interface.

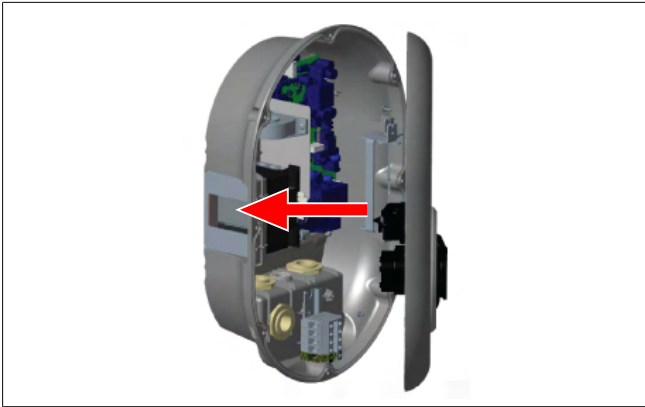

Fig. 31

4. Close the product cover as described in the installation manual.



Fig. 32

5. Open the hinged lid of the outlet socket.

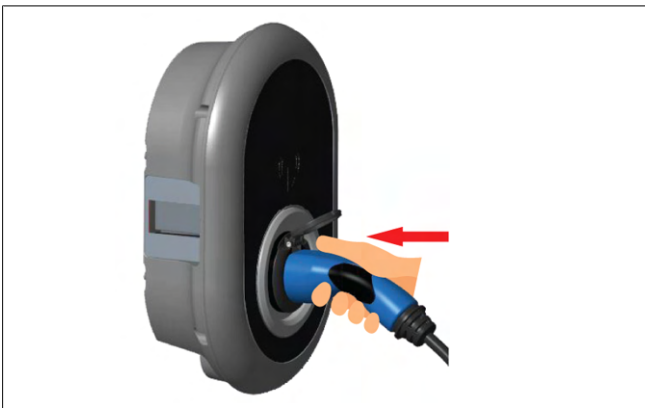

Fig. 33

6. Plug the charging cable plug into the outlet socket.

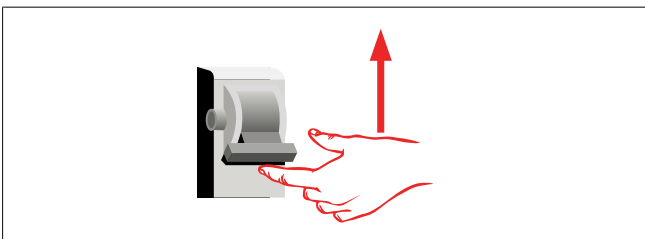

Fig. 34

7. Turn on the power to your charging station. The cable becomes locked and the charging station starts behaving as a cable model.

### 6.7.4 Power optimizer / external meter (requires optional accessories)

The power optimizer / external meter feature is provided with optional metering accessories which are sold separately.

#### Compatible external meters

Check the online documentation for compatible external meters.

In power optimizer mode, the total current drawn (by the charging station and other household appliances) from the mains switch of the house is measured with a current sensor integrated into the main power line. The current limit of the system's mains power line is set through the DIP switches inside the charging station according to the limit set by the user. The charging station dynamically adjusts its output charging current according to the measurement of the mains power line.

The current limiter settings determine the maximum permissible current at the grid connection point or at the meter's installation location. The maximum current for the charging station is then dynamically adjusted to not exceed the maximum current at the grid connection point.

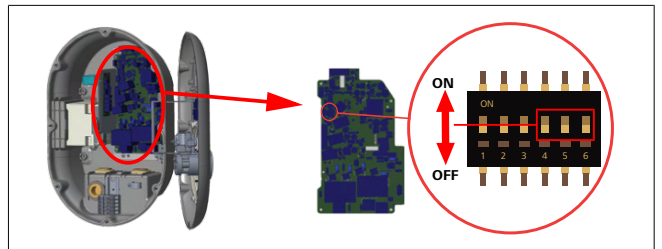

Fig. 35

DIP switch positions 4, 5 and 6 correspond to the binary digits of the maximum current value, as shown in the table below. When DIP switches 4, 5 and 6 are in the **OFF** position, then the power optimizer functionality is **disabled**.

DIP switch 4	DIP switch 5	DIP switch 6	Current limit value
OFF	OFF	OFF	Power optimizer disabled
OFF	OFF	ON	16
OFF	ON	OFF	20
OFF	ON	ON	25
ON	OFF	OFF	32
ON	OFF	ON	40
ON	ON	OFF	63
ON	ON	ON	80

#### NOTE

##### DIP-switch settings

DIP-switch settings are optional. All settings can be changed by using the Setup App, or the web configuration interface (see chapter 8, "Unite Configuration Interface" on page 20).

- ▶ The most recent made setting will always be applied.
- ▶ The current setting is shown in the web configuration interface.

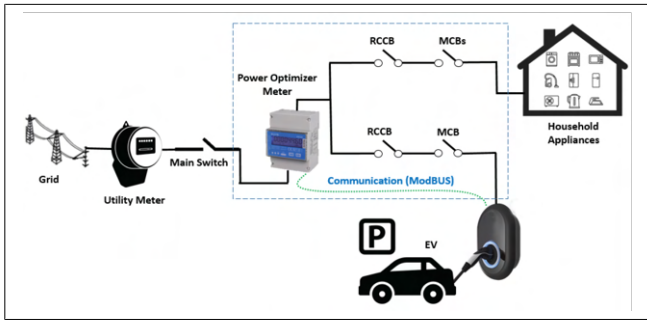

Fig. 36

The power optimizer meter must be installed just *after* the mains switch of the house, as shown in the illustration above.

1. Install the power optimizer meter
2. Install the wiring according to the figure and table below.

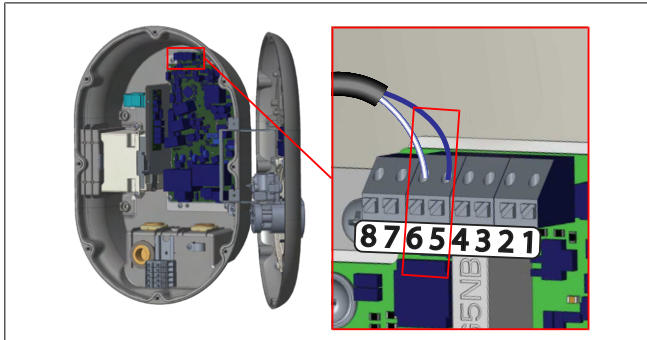

Fig. 37

Terminal	Description
5 (CN20-1)	B (COM)
6 (CN20-2)	A (COM)

### 6.8 Using the Mode selection switch

The Webasto Unite has the following modes:

- **Operation Mode 1** (Standard Charging): This mode is the factory default setting.
- **Operation Mode 2** No function
- **Operation Mode 3** No function

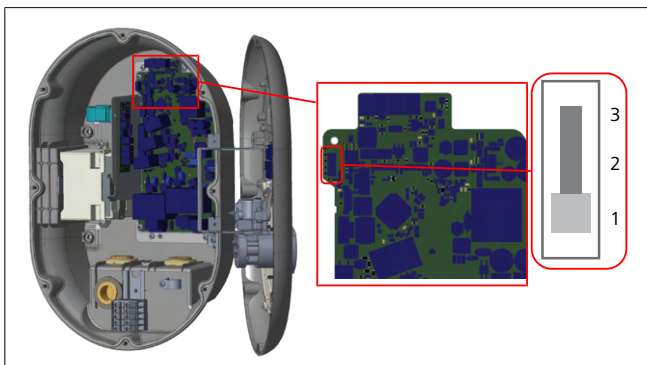

Fig. 38

- The mode selection switch must be in position 1.

### 6.9 Setting up Load shedding / Potential-free contact

The Webasto Unite supports load shedding. Load shedding provides immediate charging-current reduction in case of limited supply. Load shedding can be used in any mode, including *Standalone* and *OCPP-connected* modes. The load-shedding triggering signal is a dry contact, (potential free) signal. This signal must be provided externally, and must be connected to terminals 3 and 4 on the power board.

- When load shedding is activated by closing the contacts with an external device (such as ripple control receivers), then the charging current is reduced to 8 A.
- When load shedding is deactivated by opening the contacts, then the charging process continues at the maximum available current.
- In a normal state, when there is no signal connected to the load shedding input (contacts open between terminal 3 and 4), the charging station supplies the maximum available current.

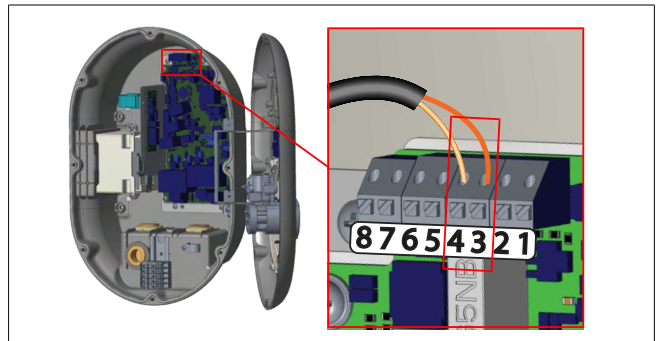

Fig. 39

Terminal	Input
3	Load Shedding Input +
4	Load Shedding Input -

Load Shedding Input State	Behaviour
Open Contact	Charge with maximum available current.
Closed Contact	Charge with 8 A.

- Connect the potential free contact load-shedding signal.



## 6.10 Monitoring welded relay contact failures

In accordance with IEC 61851-1 and EV/ZE Ready requirements, the Webasto Unite has a welded contactor sensing function. If a welded contact occurs, then the main board provides a shunt trip 230 V signal. Note that the CN33 connector output terminals must be used to detect welded contact failure for the relays. In case of a welded contact for the relays, the CN33 connector output will be 230 V AC. The output which has 230V AC must be connected to a shunt trip for RCCB triggering as shown below.

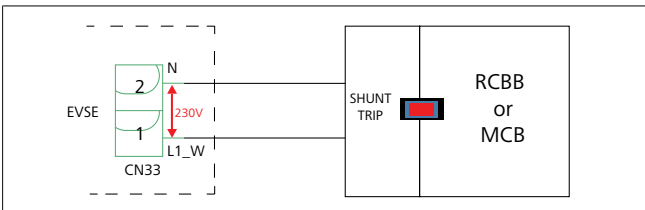

Fig. 40

The cabling must be done as shown below. The connector (CN33) terminals must be connected to a shunt trip module. The shunt Trip module is mechanically coupled to an RCCB (or MCB) at the fuse box of the charging station.

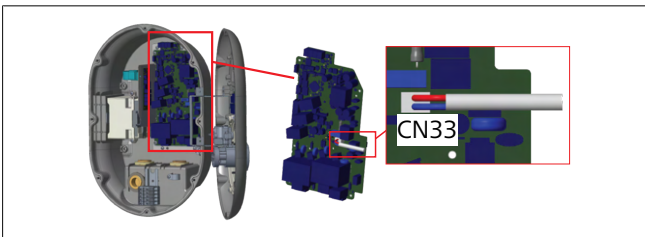

Fig. 41

Connect the shunt trip module to the charging station

## 6.11 Resetting RFID card lists and registering new master RFID cards

This section explains how to reset the local RFID card list and how to register new master RFID cards in standalone usage mode. If you have lost your master RFID card and need to define a new master RFID card, then a qualified service technician must follow these steps:

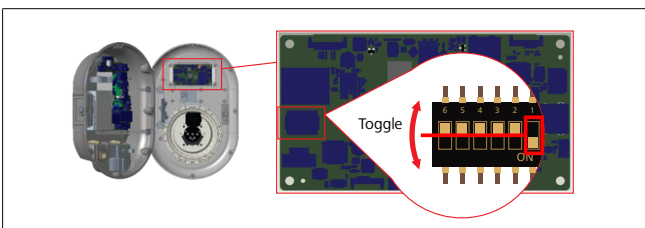

Fig. 42

1. Switch off the charging station.
2. Open the charging station's front cover.
3. Toggle DIP switch number **1**.
4. Close the charging station's front cover.
5. Switch on the charging station again.
  - When the charger is powered on again, make sure that all previously stored master card and user card lists have been erased. If so, then the configuration mode is active for 60 seconds and the LED indicator is flashing red. The first RFID card to be registered within 60 second will be the new **master** RFID card. Follow the on-screen in-

structions to register the RFID user card which is used during the charging process.

*If the new master card is not registered within 60 seconds, then the configuration mode is cancelled and the charging station will behave as an autostart product.*

## 6.12 Configuring a charging station's Ethernet port

This section explains how to set the Ethernet port of your charging station to a static IP address in standalone usage mode. The factory default setting for your charging station is DHCP mode. If you have to connect to the charging station's web configuration interface directly by using a computer (instead of using your router's DHCP server), then follow the steps below:

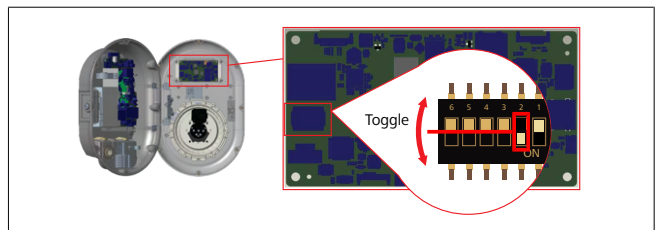

Fig. 43

1. Switch off the charging station.
2. Open the charging station's front cover.
3. Toggle DIP switch number **2**.
4. Close the charging station's front cover.
5. Switch on the charging station again.
6. The charging station now sets its Ethernet port to:
  - Static address: 192.168.0.100
  - Subnet mask: 255.255.255.0

If the charger's LAN (Local Area Network) interface has to be changed back to DHCP mode again, then you can do this from the web configuration interface (see chapter 8, "Unite Configuration Interface" on page 20).

**NOTE**  
You can also use the factory reset function to set the LAN interface back to DHCP mode. Note however that **all other parameters** will also be reset to factory default.

## 6.13 Enabling and disabling the web configuration interface

To enable or disable the Web Configuration Interface:

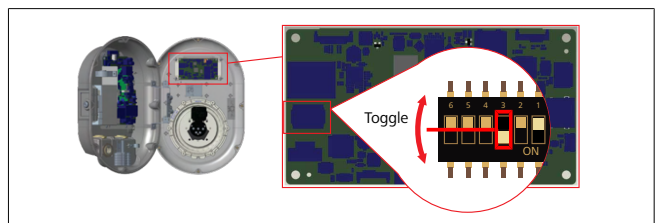

Fig. 44

1. Switch off the charging station.
2. Open the charging station's front cover.
3. Put DIP switch number **3**
  - in the **OFF** position to **disable** the web configuration interface.

- in the **ON** position to **enable** the web configuration interface.
4. Close the charging station's front cover.
  5. Switch on the charging station again.

## 6.14 Configuring an OCPP connection

### 6.14.1 Connecting OCPP via Ethernet



Fig. 45

1. Feed the Ethernet cable through the cable gland as shown above.

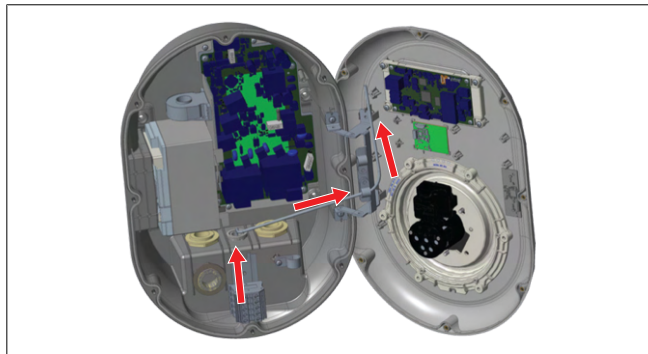

Fig. 46

2. Pull the Ethernet cable through the cable clamps as shown by the arrows above.

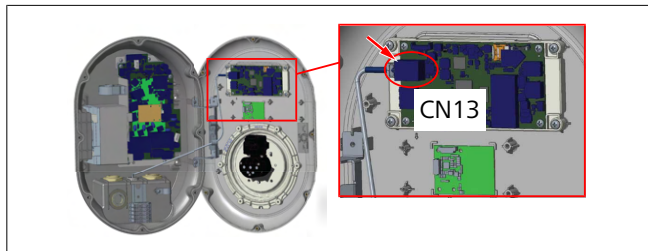

Fig. 47

3. Insert the RJ45 connector into the socket as shown in figure below.

## 6.15 Final step

After completing all relevant installation and configuration steps and **before powering up the charging station**, you must close the front cover.

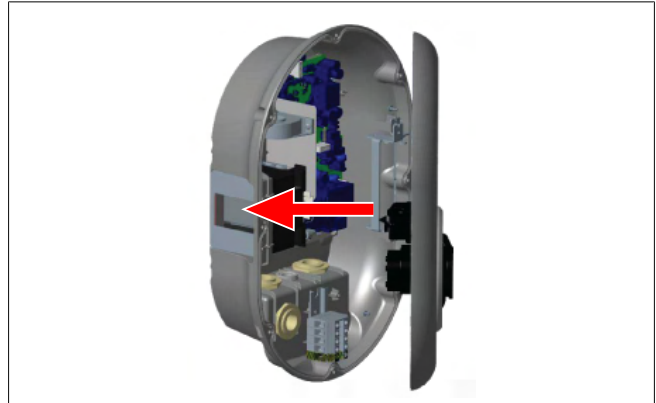

Fig. 48

1. Close the charging station cover.
2. Mount all 8 cover screws (which were removed at the beginning of the installation).
  - Tighten all cover screws, using a Torx T20 Security L-wrench or a right-angle screwdriver adapter with a Torx T20 Security bit.

## 7 Commissioning the charging station

You can connect your computer to the charging station to access the web configuration interface in the following ways:

- **Indirectly** by using a router with a DHCP server.
- Using this option, you must connect the charging station as well as the computer to the router. You must check your router's IP address because you need this to make a connection.
- **Directly** via an Ethernet patch cable
- Connect your computer directly to the charging station using an Ethernet patch cable.

In this case, make sure that:

- you have configured the charging station's LAN interface to a static IP. See chapter 6.12, "Configuring a charging station's Ethernet port" on page 17.
- you have enabled your charging station's web configuration interface via a DIP switch setting. The web configuration interface is enabled by default. See chapter 6.13, "Enabling and disabling the web configuration interface" on page 17.

### 7.1 Connecting your computer and your smart board to the same network

To access the web configuration interface, first connect your computer and charging station to the same Ethernet switch or router.

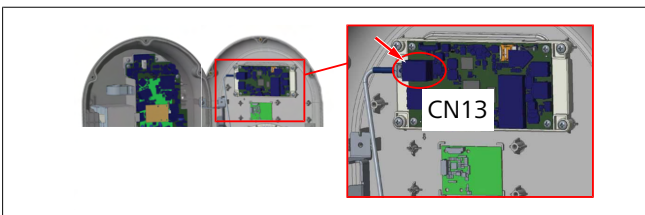

- Alternatively, connect the charging station to your computer directly.

The default IP address of the HMI board is 192.168.0.100. This is why you must assign a static IP address to your computer, which must also be in the same network as the HMI (Human Machine Interface) board. To assign a static IP address in the 192.168.0.254 network to your computer, the IP address must be in the 192.168.0.1 - 192.168.0.254 range.

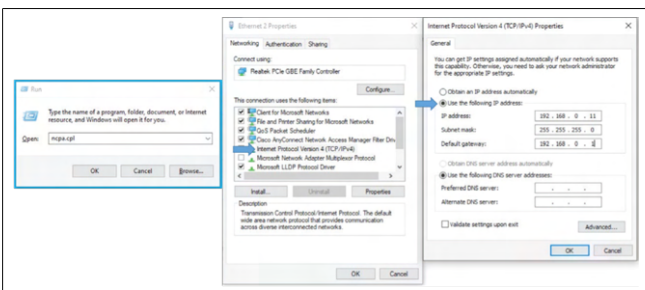

### 7.2 Accessing the Unite configuration interface using a web browser

Open your web browser, and in the address bar enter the IP address (**192.168.0.100**) of the smart board. Press Enter to open the login page in your browser.

When accessing the web configuration interface for the first time, you will see the warning:

"We recommend you change your default password from System maintenance menu".

Your default login credentials are at the front of this document on a 'blank' page with a sticker showing your *username* and *password*.

Click the **Change Password** Button on the login page, or the "Administration Password" section under the "System Maintenance" menu, to change your password.

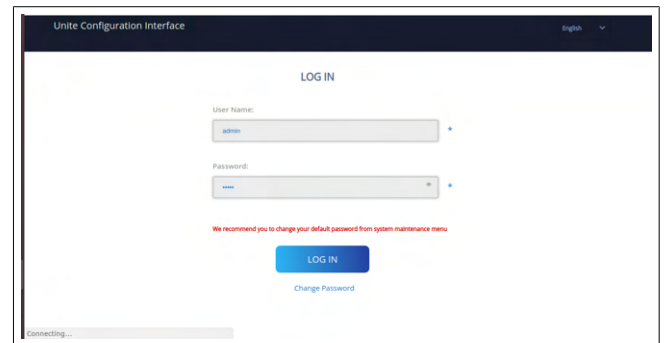

**NOTE:** In case of accessibility problems when using the web configuration interface, note that web browsers usually save access information from websites in the form of cache and cookies. Forcing a refresh (by pressing **F5**) or a clean (depending on your operating system and browser) often fixes problems surrounding page loading and formatting.

Should problems persist, please google: *clearing browser cache*.

### 7.3 Accessing the Unite configuration interface via Wi-Fi hotspot

After connecting to the "Wi-Fi Hotspot" network, open the web browser on your computer or mobile device, and then enter the charging station's IP address (**172.20.0.1**).

- For **Android** mobile devices, configure your Chrome browser to download and display the **desktop** site. Click the 'more' menu (☰) in the upper right corner of your screen, and then click **Desktop site**.
- For **iOS** mobile devices, configure your Safari browser to download and display the **desktop** site. Click the 'aA' menu in the upper left corner of your screen, and then click **Request Desktop Website**. To set the text size to 50% click the smaller **A** at the top left of the 'aA' menu.

Enter your user credentials for connection, to access the login page of the web configuration interface in your browser. See also the below example.

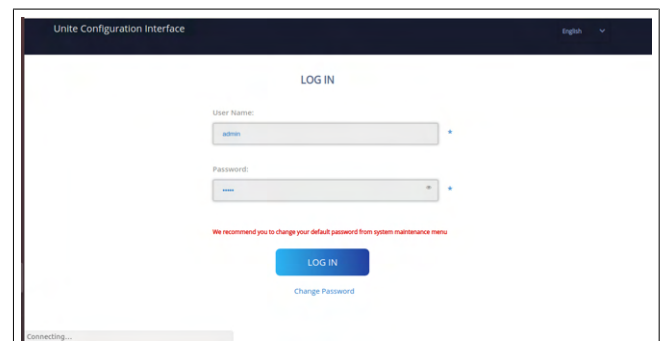

Your default login credentials are at the front of this document on a 'blank' page with a sticker showing your *username* and *password*.



**NOTE**

**Wi-Fi hotspot limitations**

- ▶ The web configuration interface via Wi-Fi hotspot is limited to a maximum of 3 users.
- ▶ The web configuration interface via Wi-Fi hotspot only works on the 2.4 GHz band.

## 8 Unite Configuration Interface

The Unite Configuration Interface has a horizontal top menu bar which provides the following functions:

- **Logout**  
The **Log out** button on the upper right corner of the screen enables you to exit the User Configuration Interface. log out.
- **Change password**
- **Display language**  
The drop-down list on the left of the **Log out** button enables you to change the web configuration interface language.

Available languages are: Czech, Danish, English, French, German, Hungarian, Italian, Norwegian, Polish, Romanian, Slovakian, Spanish, Swedish, Turkish.

The boxes are configured in English by default.

The top bar also provides access to the following pages:

- Main Page - see also: chapter 8.1, "Main page" on page 20.
- General Settings - see also: chapter 8.2, "General Settings" on page 20
- Installation Settings see also: chapter 8.3, "Installation Settings" on page 20
- OCPP Settings - see also: chapter 8.4, "OCPP Settings" on page 22
- Network Interfaces - see also: chapter 8.5, "Network Interfaces" on page 22
- Standalone Mode - see also: chapter 8.6, "Standalone Mode" on page 23
- Local Load Management
- System Maintenance - see also: chapter 8.8, "System Maintenance" on page 25
- Firmware Update Screen Flow

### 8.1 Main page

After logging in successfully, you are directed to the main page.

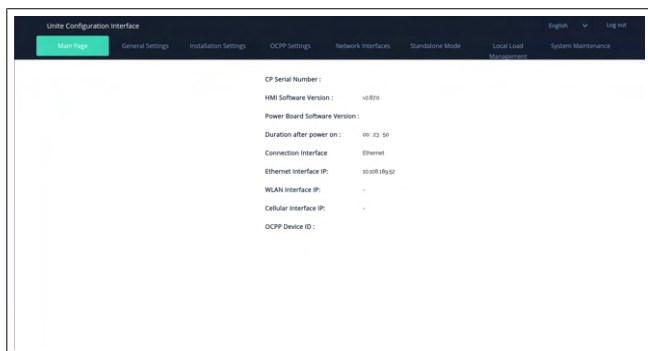

The main page shows general information about the device such as **software versions**, **connection interface** and **IDs**.

## 8.2 General Settings

### 8.2.1 Setting the LED dimmer

To adjust the brightness level of the LED ring, select the desired option in the drop-down list.

If you select the LED dimming level as "Time Based", then the options "Sunrise Time" and "Sunset Time" are shown and can be configured. "Sunrise Time" defines the transition time of low to high dimming level. Similarly, "Sunset Time" defines the transition time of high to low dimming level. Sunrise and sunset time-based configuration is a periodic daily setting.

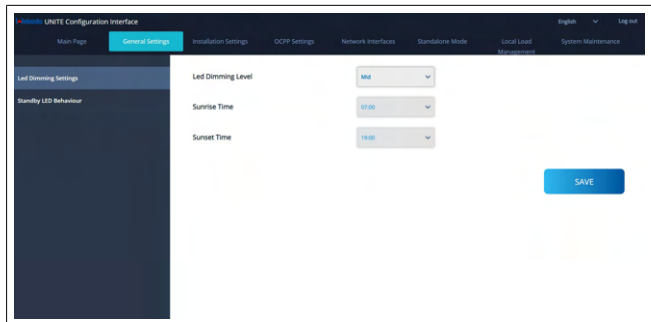

### 8.2.2 Setting the standby LED behavior

To enable standby LED behaviour, select "On" in the drop-down list. When set to "Off" the LED indicator is not illuminated when in standby. The default setting is "On".

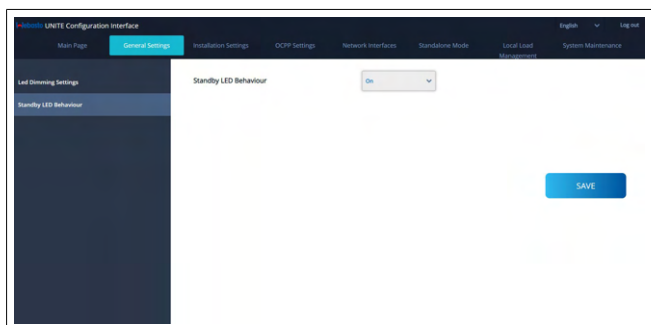

## 8.3 Installation Settings

### 8.3.1 Earthing system

Select the **Earthing System** tab from the web configuration interface.

If you select earthing type **IT**, then the protective earth error check is disabled.

The earthing type is set to **TN/TT** by default in the web configuration interface.

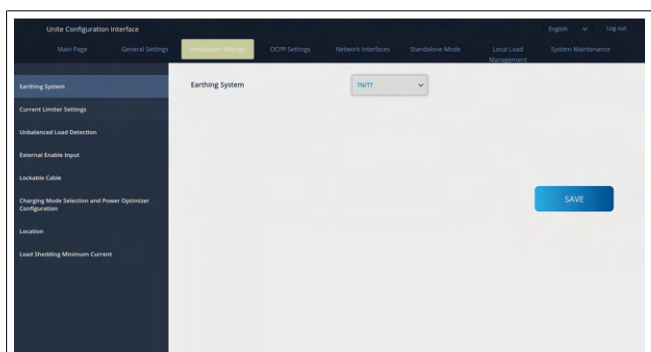

### 8.3.2 Current limiter settings

Here you can set the number of installed phases and the maximum current limit. Please note that incorrect setting of the installed phases (e.g. setting three phases when actually only one phase is installed) will cause the charging station to go into failure mode.

The current limiter value can be manually set between 6 – 32 A. If a value below 6 A is entered, a warning will be shown to enter a minimum of 6 A.

Example: If the charging station’s current limiter is set to 16 A in the hardware and it is entered and set to 32 A in the web configuration interface, then the station will take 16 A.

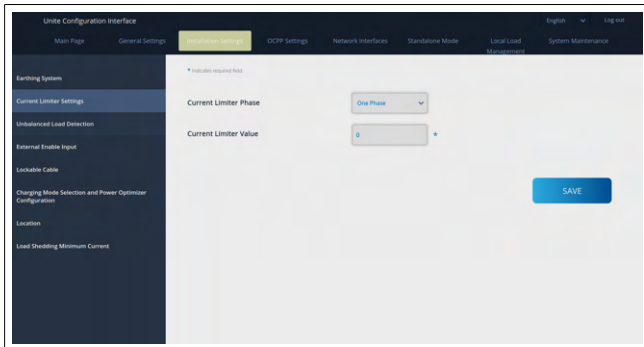

### 8.3.3 Unbalanced load detection

**Unbalanced load detection** is disabled in web configuration user interface by default.

The unbalanced load detection function detects if there is an excessive difference in power consumption between phases.

If one phase draws more than 4.6 kW of power (average of the last minute) than the other phases in one minute, the load is unbalanced. Unbalanced load detection detects this situation and the current is limited so that the phases do not exceed the power limit.

For example,

- Phase 1 power :3 kW,
- Phase 2 power :3 kW,
- Phase 3 power: 1 kW.

The power limit for phase 1 or phase 2 is 5.6 kW (1 kW + 4.6 kW)

If the voltage is 230 V, the current limit is  $5600 / 230 = 24$  A.

General formula:

Power limit = (Minimum Power + 4.6) (kW)

Current limit = Power Limit / Voltage (Amps)

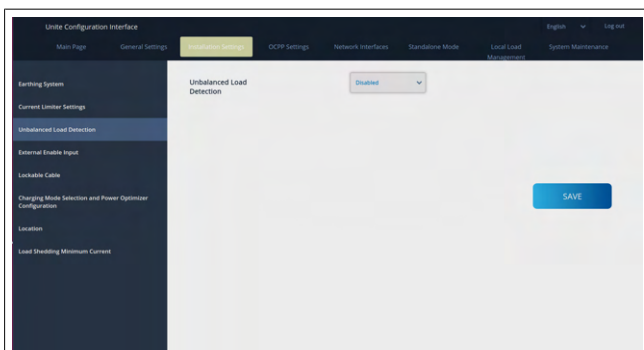

### 8.3.4 External Input / Dry contact enabled

This option is set to “disabled” by default.

If you want to use the external enable input function, then you must change this setting to “enabled”

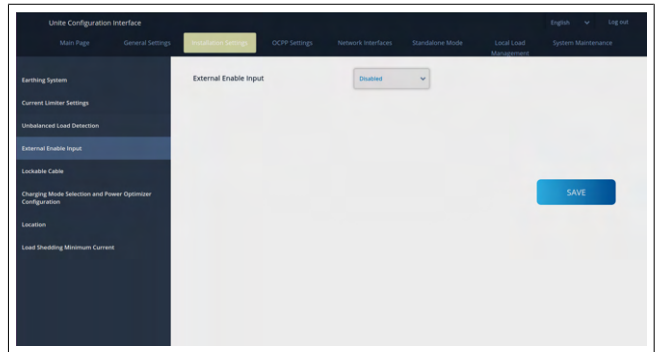

### 8.3.5 Lockable cable

This option is set to “disabled” in the web configuration user interface. This is the default setting.

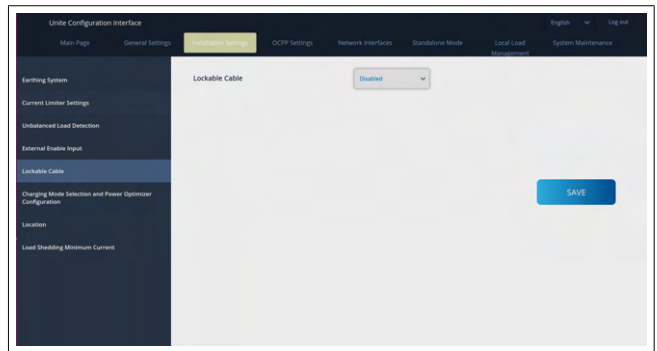

### 8.3.6 Power Optimizer/dynamic load management

For Power Optimizer Total Current Limit, The value mentioned in chapter 6.7.4, "Power optimizer / external meter (requires optional accessories)" on page 15 can be set from web configuration interface as shown in figure below.

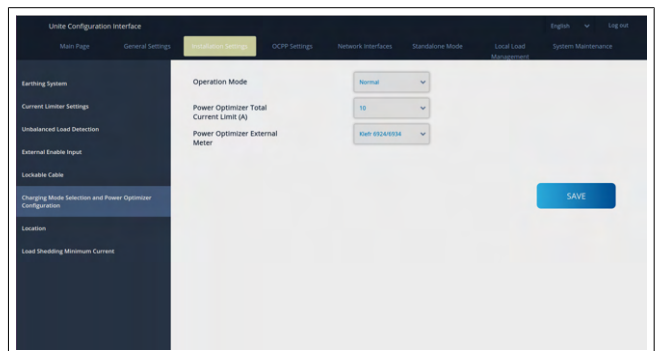

For Power Optimizer External Meter, the installed external smart meter must be selected from the drop down list.



## 8.4 OCPP Settings

### OCPP Connection

If you set the OCPP Connection mode to "Enabled" then you must complete all fields in the connection settings section and enable the configuration parameters sections.

Currently, the only available OCPP version is OCPP 1.6, so this is selected by default.

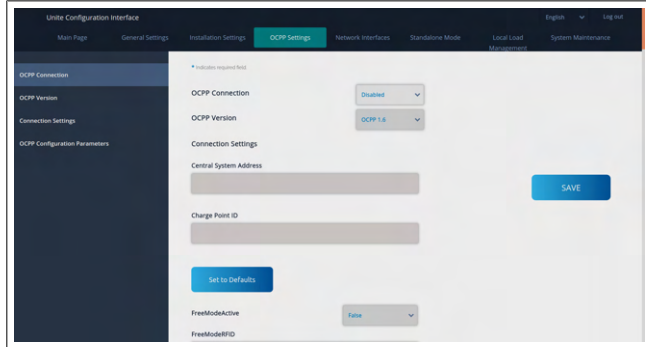

Click the **Set to Defaults** button to reset OCPP configuration parameters.

You can select the following OCPP settings type from the menu on the left of the page:

- OCPP Connection
- OCPP Version
- Connection Settings
- OCPP Configuration Parameters.

Click the **Save** button to apply your selection.

Please note that the system does not accept the unsuitable values and will return a warning. In this case, values will not be saved, after which you are then returned to the main page; so check your values.

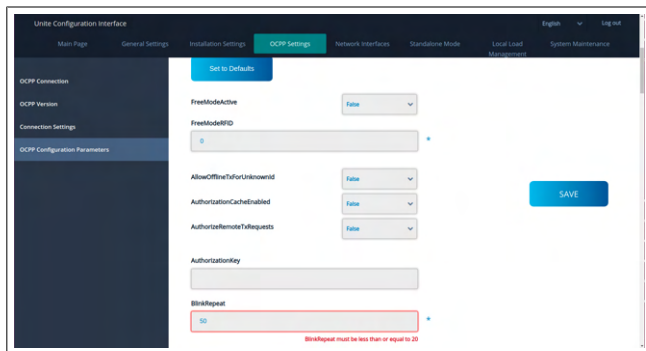

If you make any changes, and you do not save these before leaving the page, then the below warning will be returned.

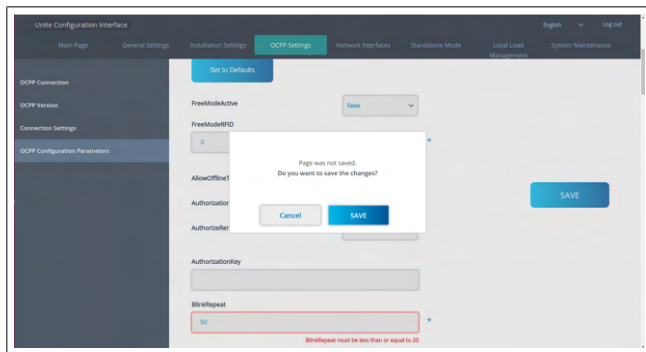

## 8.5 Network Interfaces

You can configure Ethernet and Wi-Fi on this page.

To activate an interface mode, set it to "Enabled".

If you set IP setting to "Static", blank spaces are mandatory for the fields "IP Address", "Network Mask", "Default Gateway" and "Primary DNS".

If you enable Wi-Fi, then "SSID", "Password" and "Security" are mandatory.

Complete all spaces in the suitable format.

### LAN

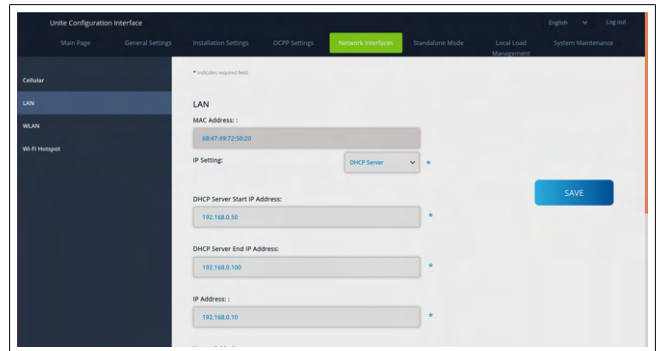

### WLAN

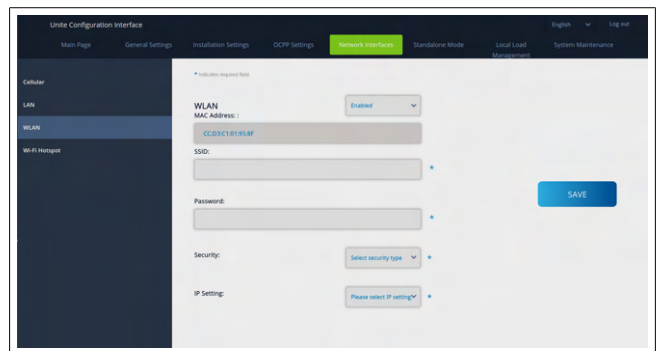

Click the **Save** button to finish.

### WIFI HOTSPOT

For details, see chapter 7.3, "Accessing the Unite configuration interface via Wi-Fi hotspot" on page 19.

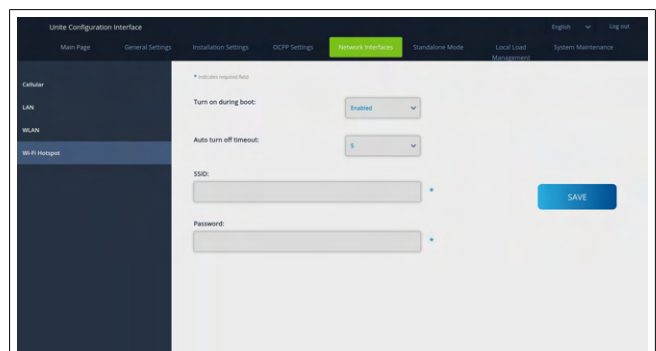

**WARNING**

If you change the SSID and Password of the WIFI Hotspot, the QR Code for the Webasto Charger Setup App will not work anymore – you must enter the credentials manually after changing these settings.

Here you can configure the behaviour of the WiFi Hotspot:

"Turn on during boot" defines the behaviour of the WiFi Hotspot when the charger starts (default is "enabled"). Enabled means that the WiFi Hotspot will be activated when the charger starts, Disabled means that the WiFi Hotspot will not be activated when the charger starts.

"Auto turn off timeout" determines whether the WiFi Hotspot remains active continuously ("Disabled") or turns off after the defined minutes selected in the dropdown menu. The default setting is "Disabled".

**NOTE**  
 If the WiFi Hotspot is disabled, you can only access the WebUI via a wired LAN connection, as explained in chapter 7.1, "Connecting your computer and your smart board to the same network" on page 19.

### 8.6 Standalone Mode

If you have enabled OCPP under the OCPP settings previously, then you cannot select standalone mode. The mode list and **Save** button are disabled in this case.

If you have not enabled OCPP, then you can select one of the following standalone modes:

- **RFID Local List** mode to authenticate an RFID local list to be entered by you. You can add or delete items from the RFID local list later.
- **Accept All RFIDs** mode to authenticate all RFIDs.
- **Autostart** mode to allow charging without the need for authorization. You only have to plug in to start charging.

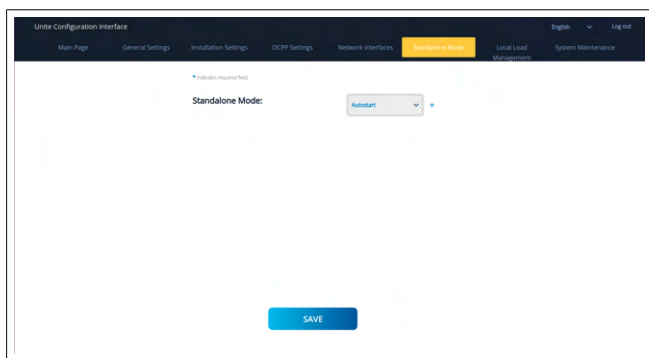

After selecting the mode, click the **Save** button and reboot the charger.

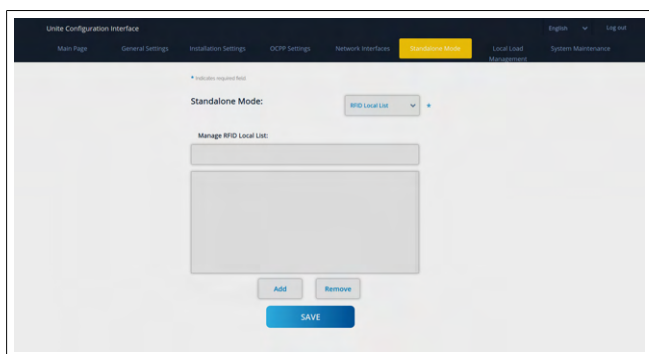

## 8.7 Local Load Management

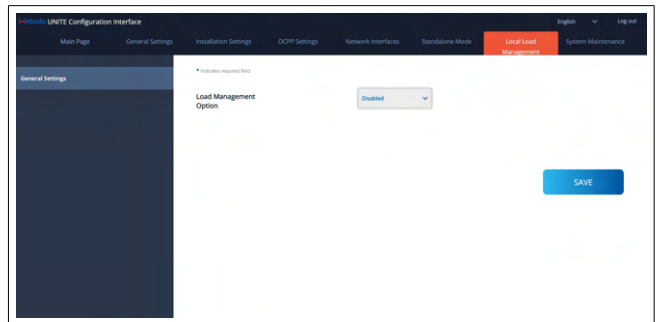

The default setting for local load management is "Disabled". Select one of the following options for Local load management from the drop-down list:

- Master/Slave
- Modbus TCP
- Disabled

**NOTE**  
 To use Local Load Management (Master/Slave or Modbus TCP), the charging stations must be connected via a wired RJ-45 LAN connection in a Star Topology using a DHCP switch or router.

### 8.7.1 Master/Slave

Load management option Master/Slave is the integrated Local Cluster Load Management functionality. After activation the configuration options become visible.

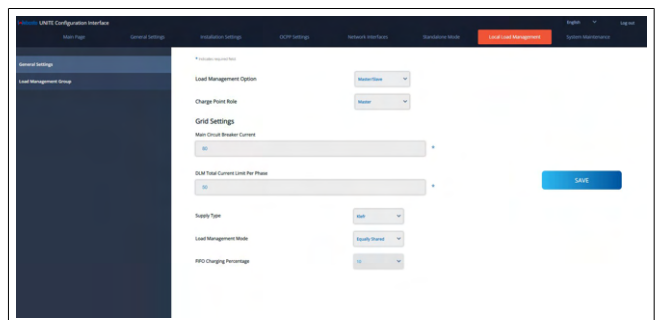

- "Charge Point Role" defines the role of the charging station within the cluster:
  - "Master" sets it to the controlling unit - if you choose to set up a dynamic load management cluster, the smart meter has to be connected to this unit.
  - "Slave" sets it to the controlled unit, which is regulated by the settings made in the Master charging station.
- "Main Circuit Breaker Current" sets the maximum current of the installed circuit breaker - this is the absolute maximum current that can be selected for the Cluster.
- "DLM Total Current Limit Per Phase" defines the maximum current available to the cluster and the total current limit must be lower or equal to the main circuit breaker current.
- "Supply Type" defines the setting of the cluster (Static or dynamic):
  - "Static" means the cluster is limited to a maximum current which will never be exceeded and the cluster is regulated accordingly.
- "Klefr" means the cluster is limited to the maximum current, but it also takes into account real time data from the externally connected Klefr meter (requires optional accessories) taking into account also other consumers in the installation (schematic see 6.7.4).

- "Garo" means the cluster is limited to the maximum current, but it also takes into account real time data from the externally connected Garo meter (requires optional accessories) taking into account also other consumers in the installation (schematic see 6.7.4).
- "Load Management Mode" defines the algorithm used to distribute the available current within the cluster:
  - "Equally shared" means the available current is distributed equally within the cluster

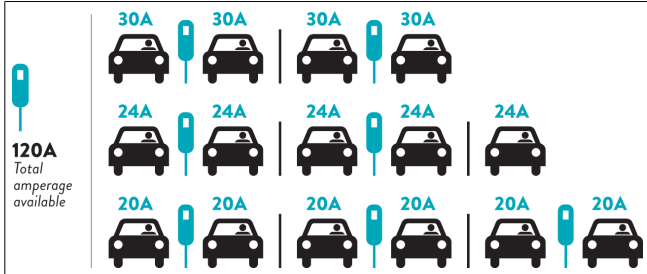

- "FIFO" means first in first out, which means vehicles connected first will receive the maximum available power and later connected vehicles get lower current, depending on the availability.

EVSE/Tp	G <sub>AV</sub> =120A						G <sub>AV</sub> =80A	
	T <sub>1</sub>	T <sub>2</sub>	T <sub>3</sub>	T <sub>4</sub>	T <sub>5</sub>	T <sub>6</sub>	T <sub>7</sub>	T <sub>8</sub>
1	32A	32A	32A	32A	16A	6A	6A	
2	32A	32A	32A	32A	32A	32A	32A	
3	32A	32A	32A	32A	32A	32A	32A	
4	32A	24A	24A	18A	32A	32A	6A	
5	32A	24A	6A	6A	8A	24A	6A	

\* T<sub>i</sub>: Time Period, G<sub>AV</sub> = Maximum Grid allocated for the chargers. Available maximum current for each EVSE in a certain T<sub>p</sub> is indicated in black color. Charging current which is drawn by EV is indicated in Blue color. An EV drawing less current is indicated by "!" symbol.

- "Combined" means the vehicles connected first are getting higher current and later connected vehicles are getting the leftover power equally distributed.

EVSE/Tp	G <sub>AV</sub> =120A						G <sub>AV</sub> =80A		G <sub>AV</sub> =29A		G <sub>AV</sub> =30A	
	T <sub>1</sub>	T <sub>2</sub>	T <sub>3</sub>	T <sub>4</sub>	T <sub>5</sub>	T <sub>6</sub>	T <sub>7</sub>	T <sub>8</sub>	T <sub>9</sub>	T <sub>10</sub>	T <sub>11</sub>	T <sub>12</sub>
1	32A	32A	32A	32A	20A	6A	6A	8A			6A	
2	32A	32A	32A	32A	32A	32A	32A	32A	11A		6A	
3	32A	32A	32A	32A	32A	32A	26A	28A	6A		6A	
4	32A	24A	24A	12A	24A	32A	8A	10A	6A		6A	
5	32A	24A	12A	12A	12A	18A	8A	10A	6A		6A	

\* T<sub>i</sub>: Time Period, G<sub>AV</sub> = Maximum Grid allocated for the chargers. Available maximum current for each EVSE in a certain T<sub>p</sub> is indicated in black color. Charging current which is drawn by EV is indicated in Blue color. A EV drawing less current is indicated by "!" symbol.

### 8.7.2 Modbus TCP (EMS)

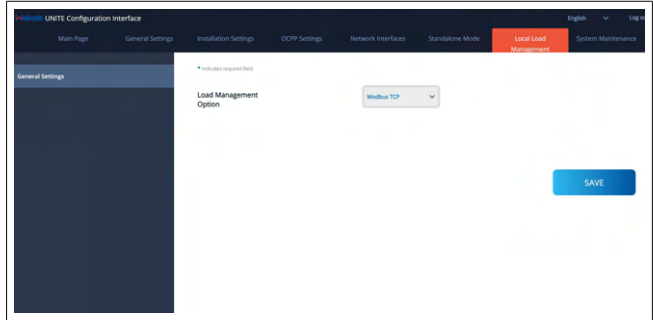

"Modbus TCP" enables the EMS mode. In this mode the charging station can be integrated into a compatible Energy Management System (Check the online documentation for compatible energy management systems). All EMS specific configurations are done via the energy management system and are communicated to the charging station via Modbus TCP.

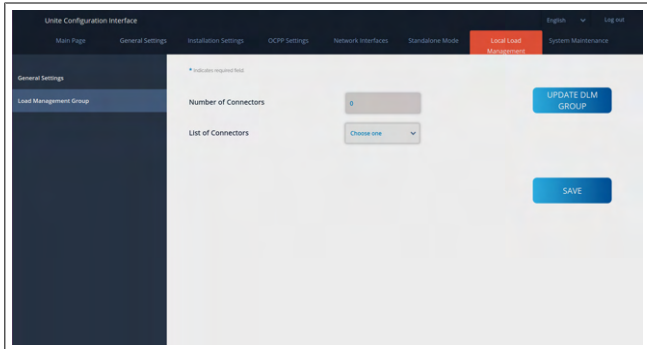

In this section you can update the DLM group via the button and then choose all charging stations that are registered within the cluster.

Various types of data can be shown in this tab.

"Phase connection sequence" defines the order of phases in case a phase rotation is implemented within the cluster.



## 8.8 System Maintenance

### LOG FILES page

Click the buttons to download OCPP or HMI logs.

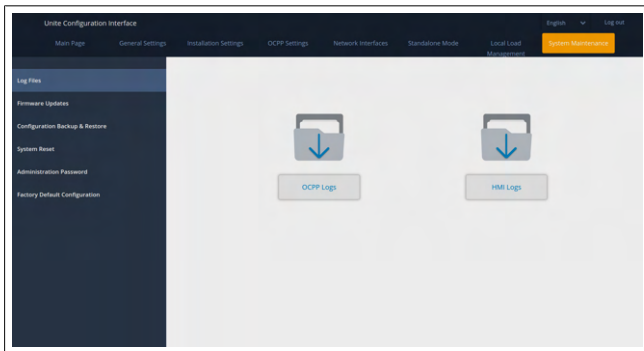

The downloaded log files are shown after a few seconds.

### FIRMWARE UPDATE page.

Click the **Upload** button to upload a firmware update file from your computer,

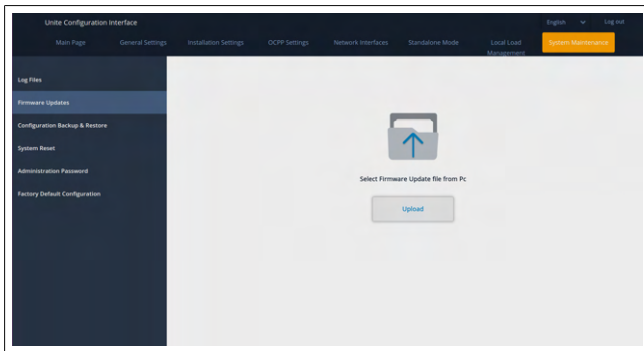

After the file is uploaded, click the **Update** button to start the firmware update.

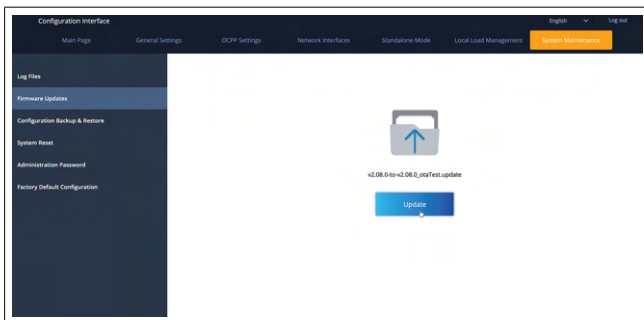

When the update is in progress, the charger's LED indicator continuously lights up in red. After the firmware update is finished, the charger restarts automatically. You can find the latest firmware version of your charger in the webconfig UI on the main page.

### CONFIGURATION AND BACKUP page

The CONFIGURATION AND BACKUP page enables you to backup the system.

To start a restore, click the **Restore Config File** button and upload the backup file. The system only accepts the .bak files.

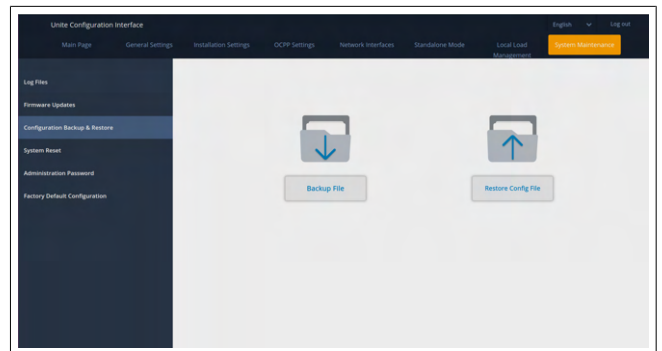

### SYSTEM RESET Page

The SYSTEM RESET Page enables you to perform a **Soft Reset** and **Hard Reset** by clicking the relevant buttons.

**Soft Reset** means that the charger is reset as soon as the charger is in its idle state.

**Hard Reset** means that the charger will reset immediately regardless of the charger's current state.

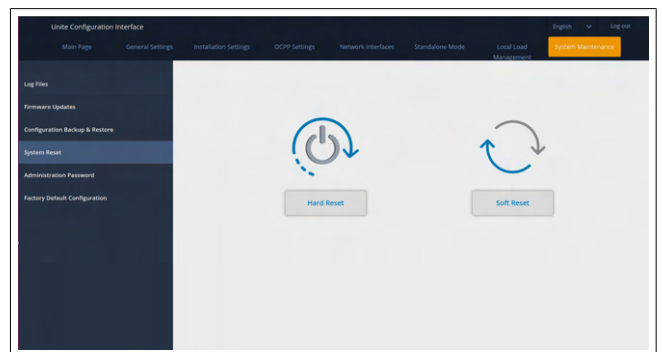

### FACTORY DEFAULT CONFIGURATION page

The FACTORY DEFAULT CONFIGURATION page enables you to apply a **factory reset** to the charger.

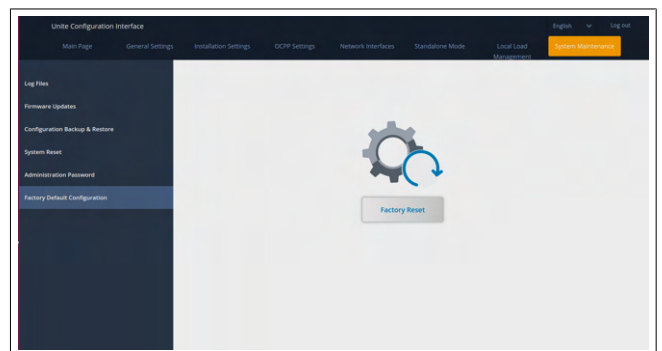

## 9 Setting up charging

### 9.1 Charging cable plug



Fig. 32

1. Open the hinged lid of the outlet socket.

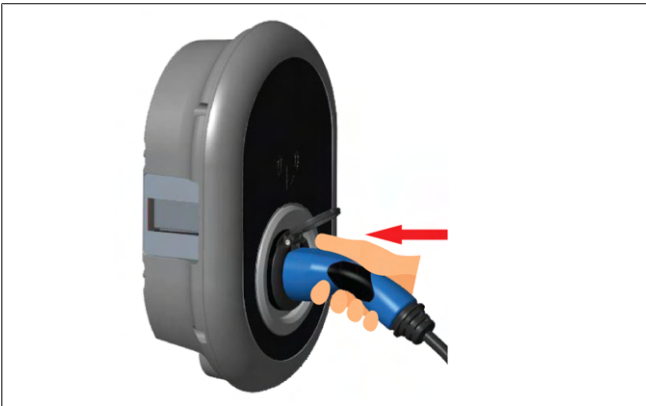

Fig. 33

2. Plug the charging cable plug into the outlet socket.

### 9.2 Reading the status information LED

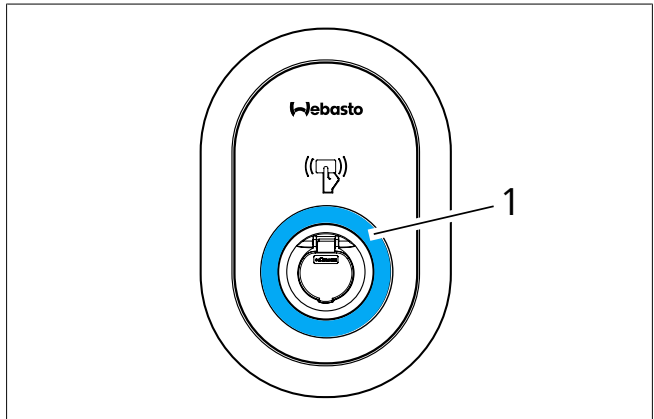



















Fig. 51

1	Status information LED
---	------------------------

LED	Description	
	Constant blue (or no LED Indication in power save mode)	The charger is ready to charge. Finished charging with RFID card.
	Blinks blue	Electric Vehicle is connected. Charging Station is waiting for RFID card authorization.
	Green glowing	Charging is authenticated.
	Blue glowing	Charging in progress.
	Constant blue	Charging suspended or finished.
	Constant red	Fault condition
	Blinks red	Ventilation required mode.
	Blinks purple	Charging current limited to 16 A due to over temperature.
	Constant purple	Charging is not possible due to over temperature, or the power optimizer current limit is reached, or the charger is disabled.
	Blinks red and blue	Charging station is reserved. Charging station is waiting for Eco Time interval. Charging station is in Delay Charge Mode.
	Constant red	Firmware update

LED		Description
	Blinks red every second for 60 seconds.	Master card config mode / Local card list reset.
	Blinks blue every 2 seconds	Waiting to tap a User RFID card or authentication/start with Webasto ChargeConnect.
	Blinks green 2 times	User RFID Card added to local RFID list.
	Blinks red 2 times	User RFID card removed from local RFID.
	Green glowing	Authorized RFID Card is tapped while the charging cable is connected.
	Glowes green for 30 seconds	An authorized RFID Card is tapped while the charging cable is not connected.
	Blinks red 3 times	Start / stop charging attempt with unauthorized RFID card.

### 9.3 Standalone / Offline Usage modes

First usage of "Standalone Usage" mode charger: Your charging station's master RFID card is already registered to your unit and you can find your master RFID card in its accessories.

1. Connect the charging cable to start charging.
2. Tap your master card to add a card.

#### 9.3.1 Autostart (Freecharging) mode

##### 9.3.1.1 Connecting & charging

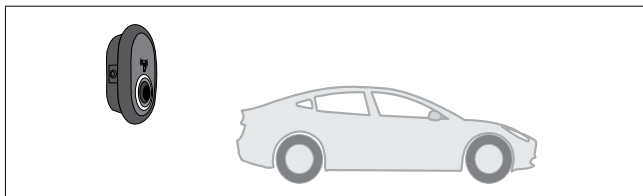



Fig. 52

-  Constant blue (or no LED Indication in power save mode)
-  mode)

Make sure that your vehicle and the charging station are ready for charging.

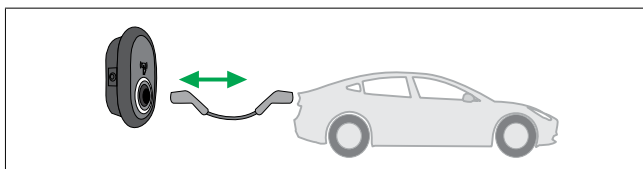



Fig. 53

-  Constant blue (or no LED Indication in power save mode)
-  mode)

Insert the charging plug into the vehicle inlet and the charging station socket outlet.

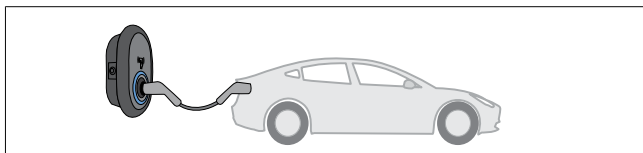

Fig. 54

-  Blue glowing

Charging starts and the status indicator LED glows blue.

##### 9.3.1.2 Stop charging

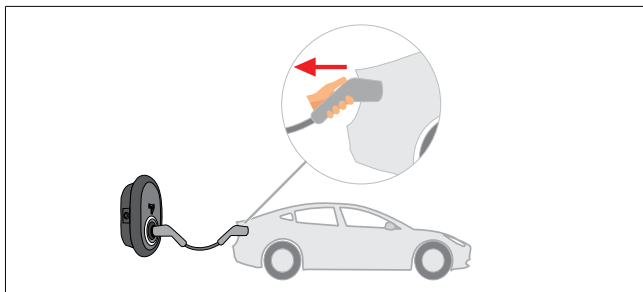



Fig. 55

-  Constant blue (or no LED Indication in power save mode)
-  mode)

Unplug the charging cable from the vehicle first.

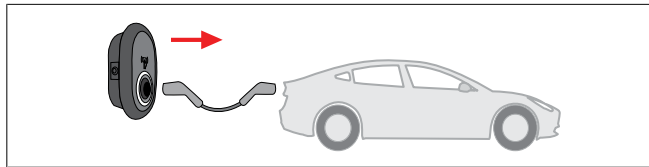

Fig. 56

- Constant blue (or no LED Indication in power save mode)
- mode)

Unplug the charging cable from the charging station.

### 9.3.2 RFID Authorisation mode

With some configuration variants, you may find RFID cards (1x master card; 2 x user cards). The master RFID-card is required for adding or deleting user RFID cards. User RFID cards are required to start or stop charging sessions.



Fig. 57

#### 9.3.2.1 Adding user RFID cards to a charging station

If you want to switch to RFID authorised mode and to register user RFID cards to the charging station, you must first tap your charging station with your master RFID card when the charging cable is not connected. After doing so, the indication LED will start to blink blue for 60 seconds. During this period you can add/delete a given user RFID card. If you do not make any configuration changes within 60 seconds, the charging station will exit from its configuration mode and will return to its previous mode. You must repeat these steps for each user RFID card addition/deletion.

#### 9.3.2.2 Vehicle connecting & charging

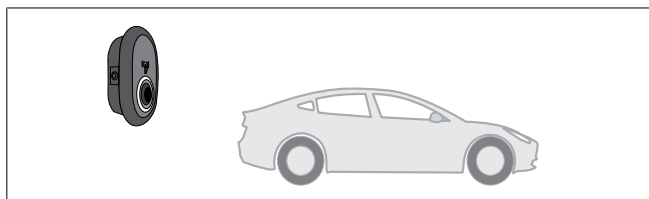

Fig. 52

- Constant blue (or no LED Indication in power save mode)
- mode)

Make sure that your vehicle and the charging station are ready for charging.

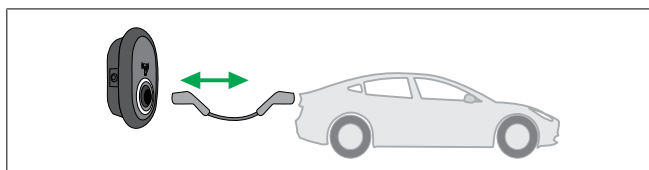

Fig. 53

- Constant blue (or no LED Indication in power save mode)
- mode)

Insert the charging plug into the vehicle inlet and the charging station socket outlet.

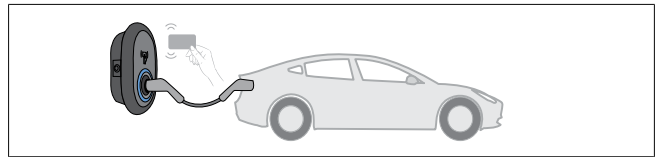

Fig. 60

- Blinks blue

Tap the user RFID card on the reader.

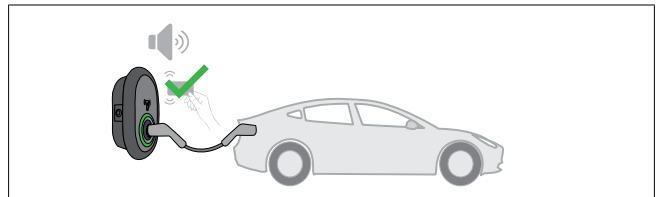

Fig. 61

- Green glowing

Start charging with a card that has been authorized before.

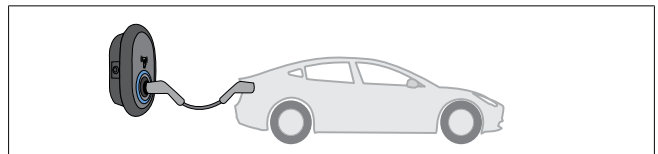

Fig. 54

- Blue glowing

Charging starts and the status indicator LED glows blue.

**NOTE**  
 Charging operation requires an authorized card  
 Charging operation is rejected by the charging station when you want to start charging with an unauthorized card.

#### 9.3.2.3 Stop charging

You must only use the following alternative methods to stop charging. Never attempt to unplug the charging cable from its charging station before stopping charging, otherwise the locking mechanism may get damaged.

##### Method 1

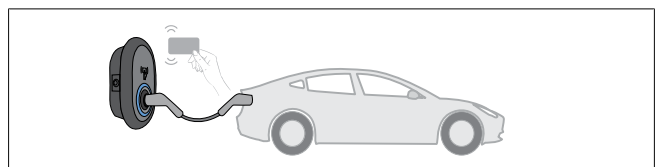

Fig. 63

- Constant Blue

You can terminate charging by tapping the RFID card that you have used to start charging.

##### Method 2

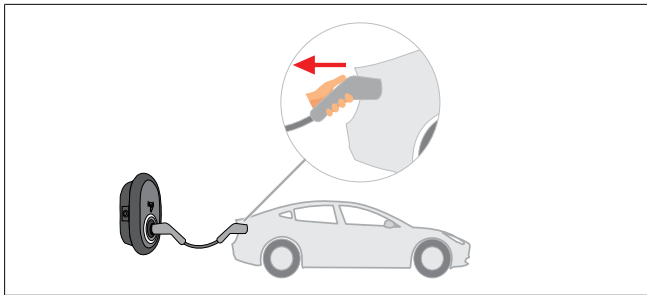

Fig. 55

- Constant blue (or no LED Indication in power save mode)
- 

Unplug the charging cable from the vehicle first.

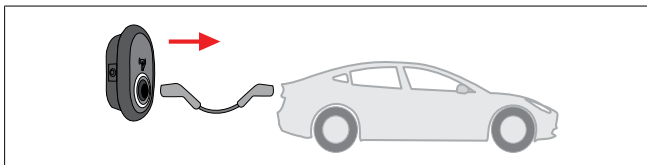

Fig. 56

- Constant blue (or no LED Indication in power save mode)
- 

Unplug the charging cable from the charging station.

### 9.4 OCPP Connected mode

WLAN and LAN use the charging station's OCPP connected mode. This is pre-configured, so this mode is used by default. In addition, the charging station is also pre-configured for Free-mode charging; it does not matter if the unit is connected to the OCPP central system or not. During installation from the Web Configuration Interface or the OCPP central system (OCPP Freemode), you must disable the Freemode setting.

#### 9.4.1 Connecting & charging

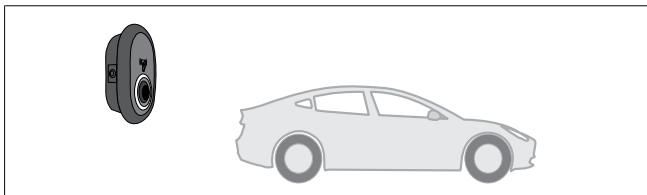

Fig. 52

- Constant blue (or no LED Indication in power save mode)
- 

Make sure that your vehicle and the charging station are ready for charging.

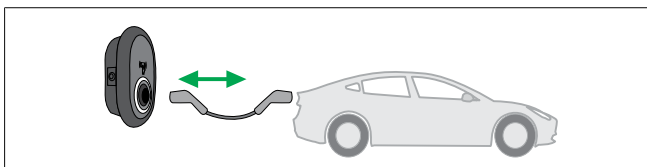

Fig. 53

- Constant blue (or no LED Indication in power save mode)
- 

Insert the charging plug into the vehicle inlet and the charging station socket outlet.

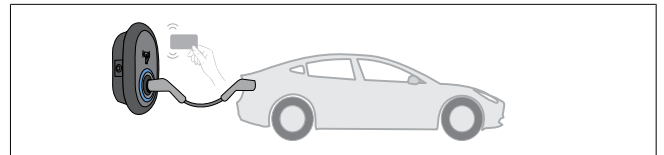

Fig. 60

- Blinks blue

Tap the RFID card on the RFID reader. You may start charging with a card which is registered with your charging operator.

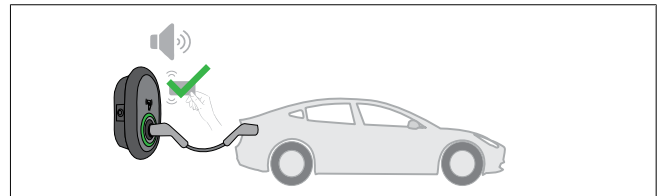

Fig. 61

- Green glowing

You may start charging with a card that has been authorized before. If the RFID Card is authorized by OCPP Central System, charging will start.

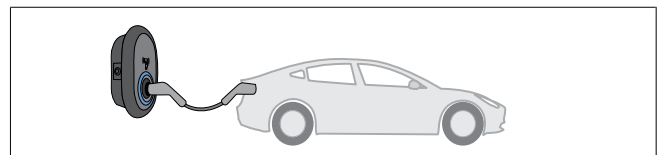

Fig. 54

- Blue glowing

Charging starts and the status indicator LED glows blue.

#### NOTE

**Charging operation requires an authorized card**

Charging operation is rejected by the charging station when you want to start charging with an unauthorized card.

#### 9.4.2 Stop charging

You must only use the following alternative methods to stop charging. Never attempt to unplug the charging cable from its charging station before stopping charging, otherwise the locking mechanism may get damaged.

##### Method 1

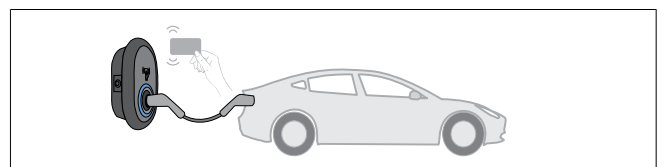

Fig. 63

- Constant Blue

You can terminate charging by tapping the RFID card that you have used to start charging.

##### Method 2

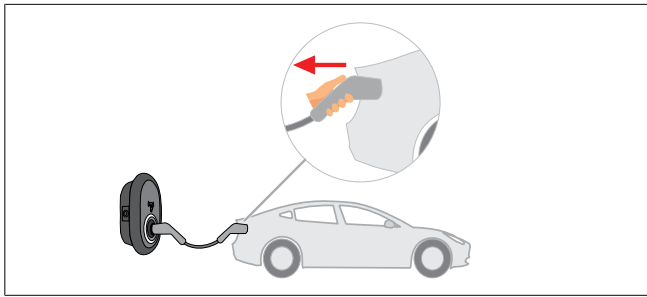

Fig. 55

- Constant blue (or no LED Indication in power save mode)
- ( )

Unplug the charging cable from the vehicle first.

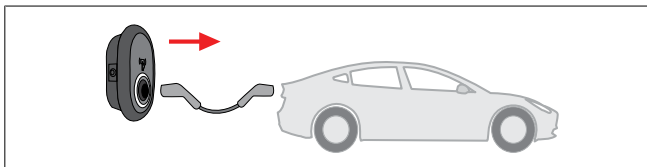

Fig. 56

- Constant blue (or no LED Indication in power save mode)
- ( )

Unplug the charging cable from the charging station.

### 9.4.3 OCPP 1.6 JSON additional features

#### 9.4.3.1 Remote charge initiation / termination

This feature is supported by the charging station. If it is also supported by the connected server, then charging process may be initiated/terminated remotely.

#### 9.4.3.2 Hard reset/soft reset

If the charging station is not working properly, the service provider may reset the appliance with this feature. There are two types of resets: Software or hardware reset may be selected.

#### 9.4.3.3 Unlocking the socket



If the charging cable is locked at the charging station, the service provider may unlock the cable via this feature.

## 10 MID meter models

The MID meter's display can show the total active energy.



# 11 Troubleshooting

Status Indicator	Problem	Possible Causes	Recommended Solutions
	Constant LED	The AC supply voltage may not be within the range of values in the Operating Instructions, A grounding connection may be absent and / or the phase / neutral connections may have been reversed, or the charging station may have a fault.	Make sure that the voltage is within the specified range and that a grounding connection is in place. If the button is still solid red, please contact your authorized service.
	Even though the status information LED blinks blue every four seconds, you cannot: - start charging the electric vehicle, or to - lock the plug into the charging station,	The charging plug may not be properly connected to the charging device or to the electric vehicle.	Make sure that the charging plug is connected properly on both ends of the cable. Make sure your electric vehicle is in charging mode.
	The status information LED blinks in red.	This error is displayed if your vehicle is equipped with a battery type that requires ventilation.	This charging station is not suitable to charge such battery types.

**NOTE**  
**Troubleshooting**  
 If you need further assistance in troubleshooting, please contact your contractual partner for support

**NOTE**  
**Wi-Fi connection issues**  
 If you have a Wi-Fi connection issue when controlling the charger, then restart your router and check the connections.

## 11.1 Resetting to factory defaults

To enable you to restore the charging station to its factory default settings, the HMI board features a reset button.

**WARNING**  
 Factory reset of the charging station must only be carried out by a qualified electrician.  
 ► After a factory reset, all configuration settings must be set again.

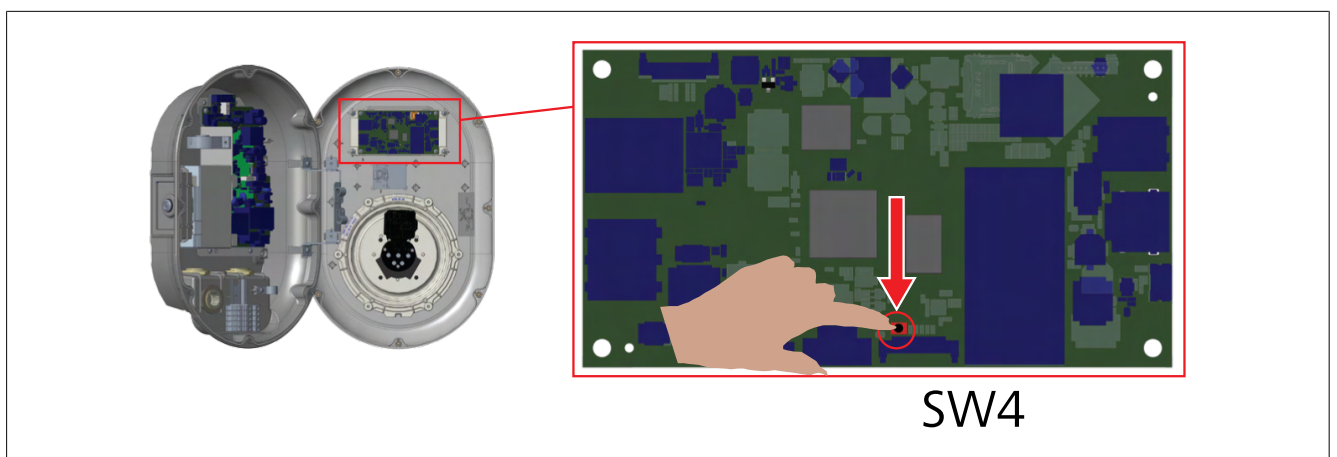

► Press the button for 5 seconds to reset the user configuration to its factory default settings. The OCPP configuration and the network configuration will revert to the factory default settings.

## 11.2 General error condition

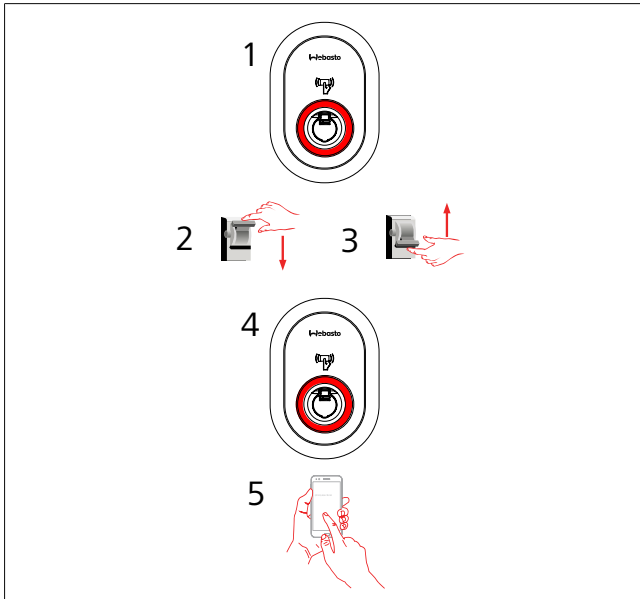

If the status information LED is constantly red (1), then turn off the charging station (2) and turn it on again (3). If the LED is still constantly red (4), then call (5) an authorized service provider.

### 11.3 DC 6 mA leakage current sensor behavior

This charging station is equipped with a DC leakage current sensor that reacts to DC leakage currents higher than 6 mA.

If the charging station goes into an error state due to DC leakage current, then you must:

- first unplug the charging cable from vehicle, and
- then unplug the charging cable from the charging station

to reset this error.

The 6 mA sensor inside this charging station has daily self-test for proper operation.



## 12 Disposal



The symbol of the crossed-out waste bin indicates that this electrical/electronic device must not be disposed of in household waste at the end of its service life. Dispose of the device free of charge at a local collection point for electrical/electronic devices. Addressed can be obtained from your city or local authority. Separate collection of electrical and electronic devices enables re-use, material recycling or other forms of re-utilisation of waste equipment while also avoiding the negative effects of hazardous substances which may be contained in the devices on the environment and for human health.

- Dispose of packaging in corresponding recycling container in accordance with national regulations.

Austria:

The EAG-VO ordinance in Austria incorporated EU law on waste electronic and electrical equipment into national legislation. This ordinance ensures that private households have the opportunity to return waste electronic and electrical equipment (WEEE) to public collection points free of charge. It is no longer permitted to dispose of WEEE in mixed municipal waste; instead, these must be handed in at the designated collection points. This allows functioning equipment to be reused, or valuable constituent parts of broken equipment to be recycled. The aim of this is to contribute to more efficient use of resources and more sustainable development. Moreover, it is only through separate collection that hazardous elements of the equipment (such as CFCs or mercury) can undergo sufficient treatment, thereby avoiding negative impacts on the environment and human health. There are municipal and manufacturer systems available for return and collection of your waste household equipment free of charge. An overview of available collection points can be found on the following website: <https://secure.umweltbundesamt.at/eras/registerabfrageEAGSammelstelleSearch.do>. All household electronic and electrical equipment is marked with the symbol of a crossed-out wheeled bin. This equipment may be handed in at any collection point listed under the above link, and should not be disposed of with household waste.

## 13 Declaration of Conformity

The Webasto Unite was developed, manufactured, tested and supplied in accordance with the relevant directives, regulations and standards for safety, EMC and environmental compatibility. Webasto Thermo & Comfort SE hereby declares that the radio equipment type "Charging Station Webasto Unite" is in compliance with Directive 2014/53/EU.

The full text of the EU declaration of conformity can be found at the following web address:

<https://charging.webasto.com/int/products/documentation>

## 14 Cleaning and maintenance

- Do not clean your EV charging device while charging your vehicle.
- Do not wash the device with water.
- Do not use abrasive cloths and detergents. Microfiber cloth is recommended.

Failure to follow these warnings may result in death and serious injuries. Also, it may cause damage to your device.

## 15 Technical data

### 15.1 Model description

<b>Product Type</b>	Electric Vehicle Conductive Charging System (Mode 3 Charging Station)
<b>Model Name</b>	<b>Webasto Unite * * * * *</b>
1st Asterisk (*) : Rated Power AC22: 22 kW (3-phase Supply Equipment)	
2nd Asterisk (*) RFID reader is standard equipment for all model variants: <ul style="list-style-type: none"> <li>- SW: Smart Board with Ethernet Port + Wi-Fi module with hotspot</li> </ul>	
3rd Asterisk (*) : Can be one of the following: <ul style="list-style-type: none"> <li>- 0 : No Display</li> </ul>	
4th Asterisk (*) can include combinations of the following: <ul style="list-style-type: none"> <li>- MID: Charging station with MID meter</li> <li>- EICH: Charging station with Eichrecht meter</li> </ul>	
5th Asterisk (*) can be one of the following: <ul style="list-style-type: none"> <li>- SO: with normal socket</li> <li>- SH: with shuttered socket</li> </ul>	

### 15.2 Dimensional drawings

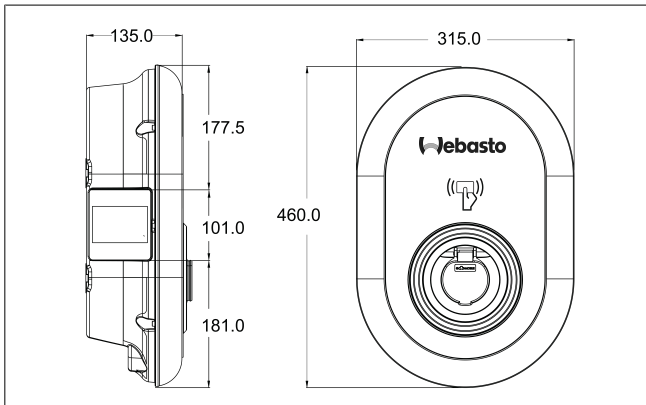

Fig. 74

### 15.3 Models



Fig. 75

#### MID Model

1	RFID card reader (Radio Frequency Identification)
2	Status indicator LED
3	Socket outlet with shutter
4	Product label
5	MID meter display (Measuring Instruments Directive 2014/32/EU)
6	Charging station supply inlet gland nut
7	Charging station communication cable gland nut
8	Charging station communication cable gland nut

#### Eichrecht model

1	RFID card reader (Radio Frequency Identification)
2	Status indicator LED
3	Socket outlet with shutter
4	Product label
5	Eichrecht meter display
6	Charging station supply inlet gland nut
7	Charging station communication cable gland nut
8	Charging station communication cable gland nut

## 15.4 Technical specifications

This product is compliant with IEC61851-1 (Ed3.0) standard for Mode 3 use.

Electrical Characteristics		Webasto Unite MID	Webasto Unite Eichrecht
IEC protection class		Class-I	
Vehicle interface	Socket Model	Socket TYPE 2 (IEC 62196)	
Rated voltage (V AC)		400 V, 3-phase 230 V, 1-phase	
Rated current (A AC)		32 A, 3-phase 32 A, 1-phase	
Grid frequency (Hz)		50 / 60	
Maximum AC charging power (kW)		22 kW, 3-phase 7.4 kW, 1-phase	
Idle power consumption (W)		3.5 W	
Built-in residual current sensing module		6 mA	
Required circuit breaker on AC mains		40 A MCB Type-C	
Required leakage current relay on AC Mains (for products not equipped with RCCB Type A)		40 A – 30 mA RCCB Type-A	
Required AC mains cable	Cross-section of the connecting cable (Cu) taking into account the local requirements and standards (min.-max.)	Rigid: 2.5-10 mm <sup>2</sup>	
		Flexible: 2.5-10 mm <sup>2</sup>	
	Max. external dimension	Flexible with wire end ferrule: 2.5-10 mm <sup>2</sup> Ø 18 – 25 mm	

Connectivity	
Ethernet	10/100 Mbps Ethernet
Wi-Fi	Wi-Fi 802.11 a/b/g/n/ac

Wi-Fi specifications				
2.4 GHz Band				
Standard	802.11b	802.11g	802.11n	802.11n
Modulation	DSS, CKK	OFDM	OFDM	OFDM
Data rate	1, 2, 5.5, 11	6, 9, 12, 18, 24, 36, 48, 54	MCS0 - 7 (HT20)	MCS0 - 7 (HT40)
Channel*	CH 1-13	CH 1-13	CH 1-13	CH 1-13
Power (dBm)	13.5	13.5	13.5	13.5
5 GHz Band				
Standard	802.11a	802.11n/ac	802.11n/ac	802.11n/ac
Modulation	DSS, CKK	OFDM	OFDM	OFDM
Data rate	6, 9, 12, 18, 24, 36, 48, 54	MCS0 - 9 (HT20)	MCS0 - 9 (HT40)	MCS0 - 9 (HT40)
Channel*	CH 36-64 / CH 100-165	CH 36-64 / CH 100-165	CH 38-62 / CH 100-159	CH 42-58 / CH 100-155
Power (dBm)	14	14	14	14

Other features (Connected models)	
Diagnostics	Diagnostics over OCPP WebconfigUI
Software update	Remote software update over OCPP WebconfigUI update Remote software update with server

Authorization	
RFID	ISO-14443A/B and ISO-15693

Mechanical specifications	
Material	Plastic
Product size	315 mm (Width) x 460 mm (Height) x 135 mm (Depth)
Dimensions (with package)	400 mm (Width) x 530 mm (Height) x 240 mm (Depth)
Product weight	5 kg

Mechanical specifications	
Weight with package	7.1 kg
AC Mains Cable Dimensions	For three-phase models Ø 18 - 25 mm For one-phase models Ø 13 - 18 mm
Cable Inlets	AC Mains / Ethernet / Modbus
Environmental technical specifications	
Protection class	IP54
Impact protection	IK10
Usage conditions	-35 °C to 55 °C (without direct sunlight) 5% - 95% (relative humidity, non-condensing) 0 - 4,000 m

## 16 Checklist for the installation of the Webasto charging station

Charging station	Webasto Unite		
Charging power	7,4 kW <input type="checkbox"/>	22 kW <input type="checkbox"/>	
Serial number			
Material number			
System type	TN/TT <input type="checkbox"/>	IT <input type="checkbox"/>	Split phase <input type="checkbox"/>

General:	Applicable/ completed
Installation, electrical connection and initial operation of the charging station must be carried out by an electrician.	<input type="checkbox"/>
The charging station has not been installed in an explosion sensitive area (EX zone).	<input type="checkbox"/>
The charging station has been installed in a location where falling objects cannot damage the charging station.	<input type="checkbox"/>
The charging station has been installed in an area protected from direct sunlight.	<input type="checkbox"/>
Please underline the weather conditions on the installation date: sun, rain, overcast, snow or other _____.	<input type="checkbox"/>
The location of the charging station should be selected such that vehicles cannot inadvertently collide with it.	<input type="checkbox"/>
The legal requirements for electrical installations, fire protection, safety regulations and escape routes have been met.	<input type="checkbox"/>
The customer/user was informed how the Webasto Unite voltage is switched off with the installation-side protective devices.	<input type="checkbox"/>
The cable bushing for the mains lead and signal cable has been installed during installation.	<input type="checkbox"/>
Tools and installation remnants have been removed from the charging station before closing the cover.	<input type="checkbox"/>
The prerequisite of a clockwise phase sequence is met during installation.	<input type="checkbox"/>
The locally applicable test logs should be drawn up during initial start-up and a copy should be given to the customer.	<input type="checkbox"/>

Electrician/contractor:	
Place:	<b>Signature:</b>
Date:	
Place:	<b>Signature:</b>
Date:	

To request this documentation in another language, please locate and contact your local Webasto dealer. You can find your nearest dealer at: <https://dealerlocator.webasto.com/en-int>.  
To provide feedback (in English or German), please email: [feedback2tdt@webasto.com](mailto:feedback2tdt@webasto.com)

Webasto Charging-Hotline:  
+800-CHARGING  
(00800-24274464)

Webasto Thermo & Comfort SE  
Postfach 1410  
82199 Gilching  
Germany

Company address:  
Friedrichshafener Str. 9  
82205 Gilching  
Germany

UK only

Webasto Thermo & Comfort UK Ltd  
Webasto House  
White Rose Way  
Doncaster Carr  
South Yorkshire  
DN4 5JH  
United Kingdom



5111967A

[www.webasto.com](http://www.webasto.com)

